



AUTOFLAME VALVES GUIDE

1. OIL CONTROL VALVES

Autoflame oil control valves are used to control the volume flow of liquid fuel to burner applications commissioned to fire on oil fuels. The oil control valves can be used with variety of oil fuels including; diesel, light fuel oil, heavy fuel oil, kerosene, methanol, biodiesel, plant oil and many others.

Oil control valves are available as spillback (bypass) or metering (simplex) and in different sizes. Each oil valve has different flow characteristics, so it is important to ensure the correct oil valve is selected for the required application to ensure correct fuel input to the burner and to utilise the full turndown capability of the burner.

For dual fuel gas/oil burner application, the oil valves can also be used with the gas valves in “piggyback” arrangement where both the gas and oil valves are controlled using a single servomotor and single MM channel.

The following oil control valves are available:

Valve Type	Pipe Thread	Spillback part #	Metering part #	Servomotor
1	1/4" BSP / NPT	OVS31015	OVM31015	Small
2	3/8" BSP / NPT	OVS32016	OVM32016	Small
3	3/4" BSP / NPT	OVS33L17	OVM33L17	Large
4	3/4" BSP / NPT	OVS34L18	OVM34L18	Large
5	3/8" BSP / NPT	OVS35019	OVM35019	Small
6	3/8" BSP / NPT	OVS36020	OVM36020	Small
8	3/8" BSP / NPT	OVS38022	OVM38022	Small
9	3/8" BSP / NPT	OVS39023	OVM39023	Small

Metering (simplex) valves are identifiable by the prefix OVM.

Spillback (bypass) valves are identifiable by the prefix OVS.

The oil control valves have the following general specifications

Specifications	
Valve body material	316 Stainless-Steel
Control bobbin material	304 Stainless-Steel
Valve mounting plates	Aluminium
O-ring type	Viton
Max. oil pressure	24 bar (350 PSI)
Max. oil temperature	120°C (248°F)

Oil control valves can be supplied in non-standard materials, please contact Autoflame to discuss your requirements.

When using high viscosity, low temperature fuel oils through smaller valves, turbulent flow characteristics can reduce volume throughput significantly.

Oil control valves can be serviced in the field, replacement O-rings can be ordered directly from Autoflame. The following part numbers can be used to order the correct set of O-rings:

Viton O-ring for small oil control valve - type 1,2,5,6,8,9	Set of 2	OR70003
Viton O-ring for large oil control valve - type 3,4	Set of 2	OR70004

1.1. Oil Valve Parts

The drawing below shows the parts forming the standard Autoflame oil control valve. The parts are the same for the spillback and metering valves.

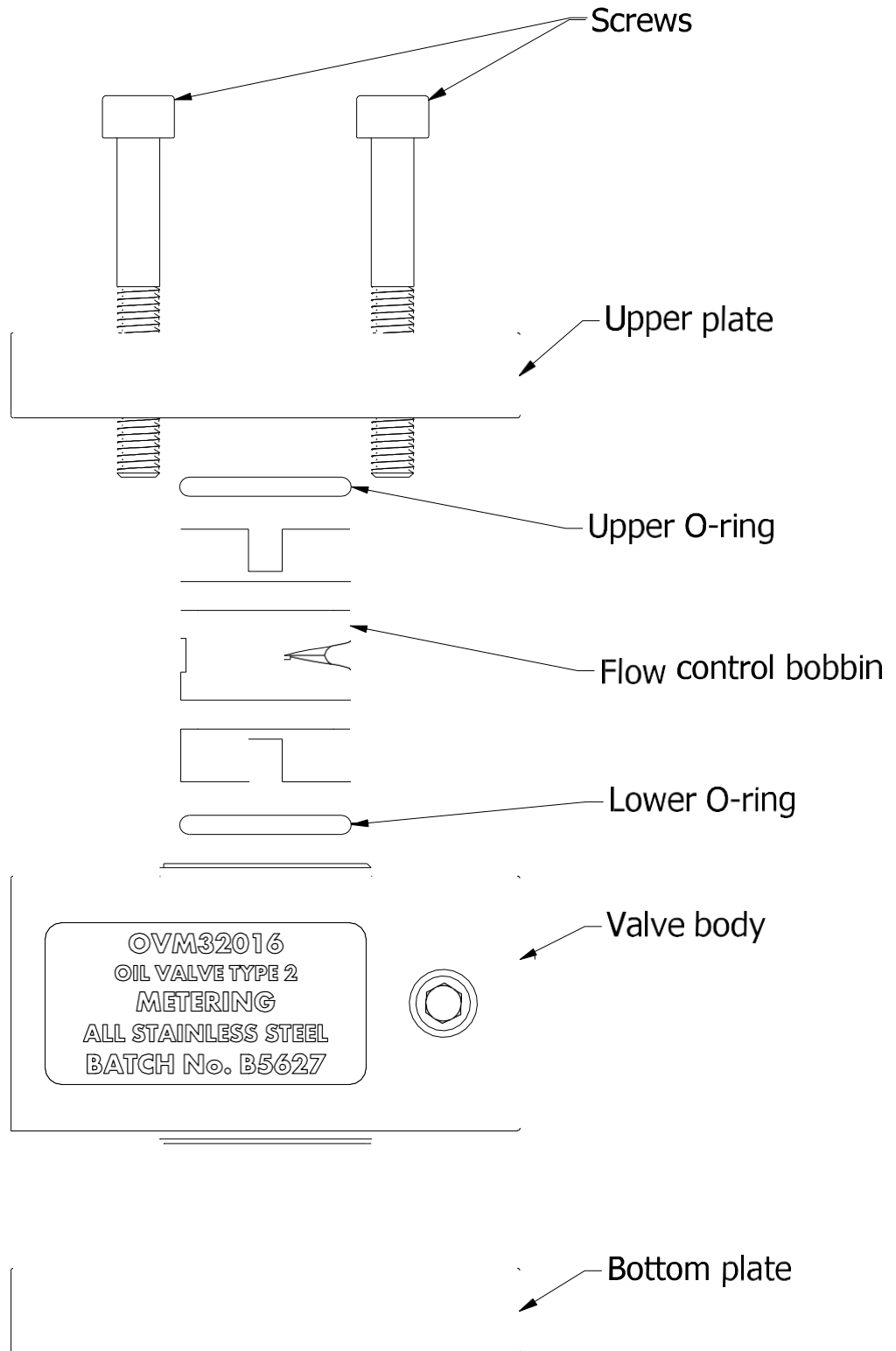

Exploded View



1.2. Oil Control Valves Applications and Sizing

1.2.1. Spillback (Bypass) Oil Valves

Spillback (bypass) oil valves are installed on the oil flow return to tank/pump and they regulate the oil flow as follows:

- When the valve is opening, more oil will flow back to the tank/pump, resulting in lower pressure at the nozzle and therefore less oil flow at the nozzle (low fire).
- When the valve is closing, less oil will be returning to the tank/pump, resulting in higher pressure at the nozzle and more oil flow at the nozzle (high fire).

The schematic below illustrates a spillback system with spillback oil control valve.

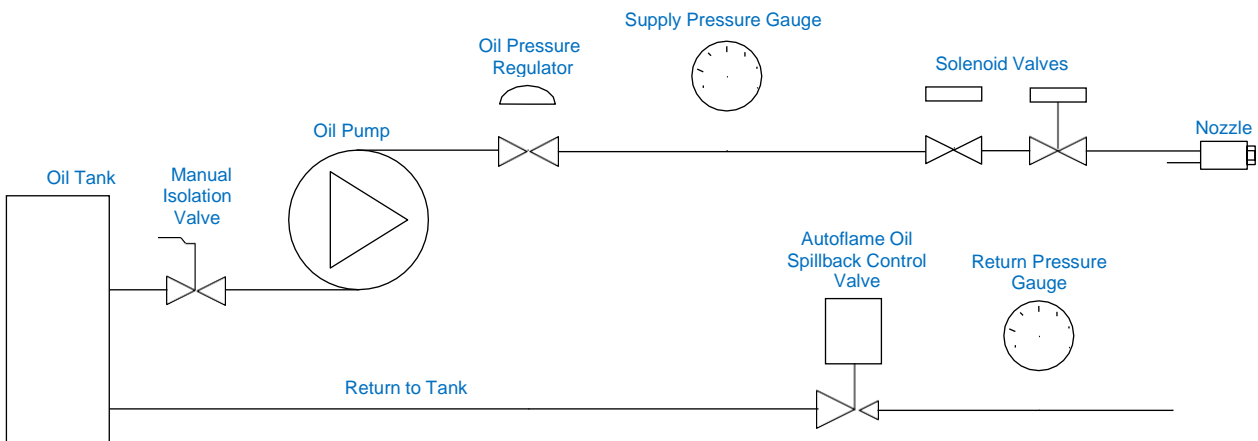

Information Required	Example Data
Oil Pump Flow Rate	1600 lb/hr
Burner Turndown Ratio	4:1
Oil Pump Pressure	450 PSI
Nozzle Flow Rate (max)	1000 lb/hr
Return Oil Pressure at Low Fire	100 PSI

In order to determine the required size of a bypass oil valve for certain application, the volume of oil and oil pressure returning to the tank/pump must be determined. The information is used to select the most suitable oil valve from the oil valves charts.

The most suitable valve is the one that allows the maximum movement (angular degrees) control range and allows the highest open position at low fire.

Using the above example data:

$$\begin{aligned}
 \text{Oil pump flow rate} &= 1600\text{lb/hr} \\
 \text{Required oil flow at low fire} &= 250\text{lb/hr (based on 4:1 turndown = } 1000/4) \\
 1600\text{lb/hr} - 250\text{lb/hr} &= 1350\text{lb/hr} \\
 \text{Spillback oil flow} &= 1350\text{lb/hr @ 100PSI}
 \end{aligned}$$

Based on the oil valves charts, the correct oil valve is type 5.

1.2.2. Metering (Simplex) Oil Valves

Metering (simplex) oil valves are installed on the main oil flow to the nozzle and regulate the oil flow as follows:

- When the valve is opening, more oil will flow back to the nozzle, resulting in higher pressure at the nozzle and therefore more oil flow at the nozzle (high fire).
- When the valve is closing, less oil will flow to the nozzle, resulting in lower pressure at the nozzle and less oil flow at the nozzle (low fire).

The schematic below illustrates the application of a metering (simplex) oil control valve.

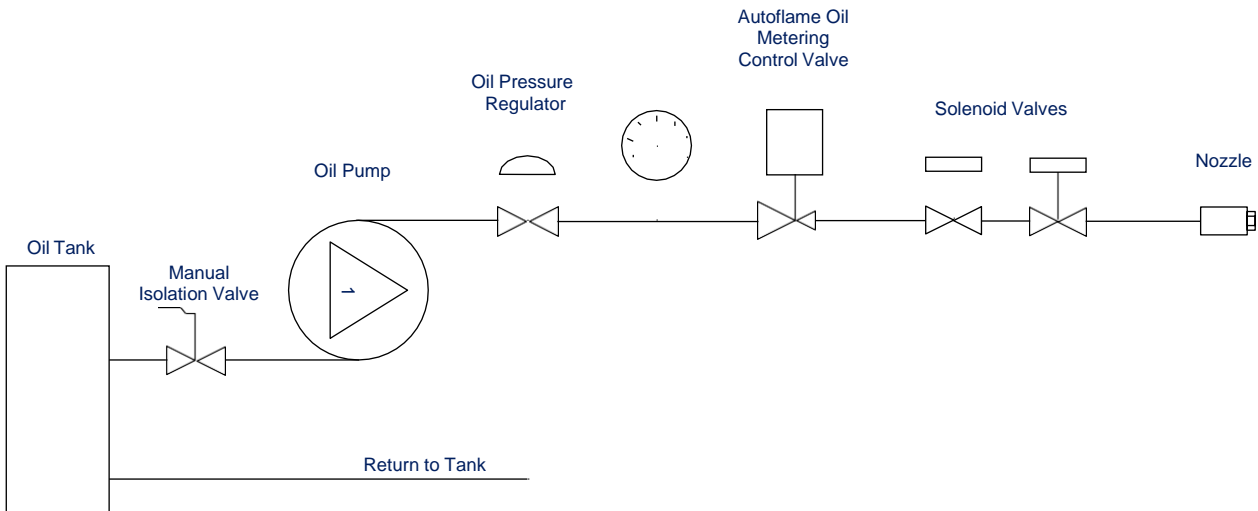

To correctly size an oil valve for metering applications, the oil pressure losses in the system must be taken into account from the original regulated oil pressure, these could include the pressure losses at:

- Nozzle
- Solenoid valves
- Any losses in the fittings after the oil control valve.

All these losses must be subtracted from the oil pressure that is used for sizing the oil valve.

The most suitable oil valve is the one which gives the maximum movement (angular degrees) of control and the most open at high fire position.

1.3. Oil Control Valves Drawings

1.3.1. Small Oil Control Valves

Small Oil Control Valve



Small Oil Control Valve with Small Servomotor

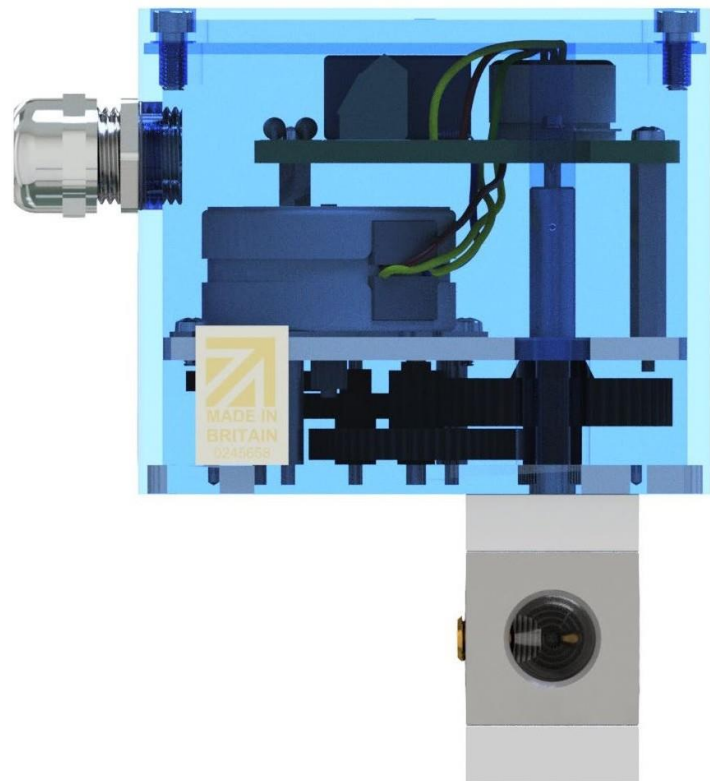

Small Oil Control Valve Dimensions

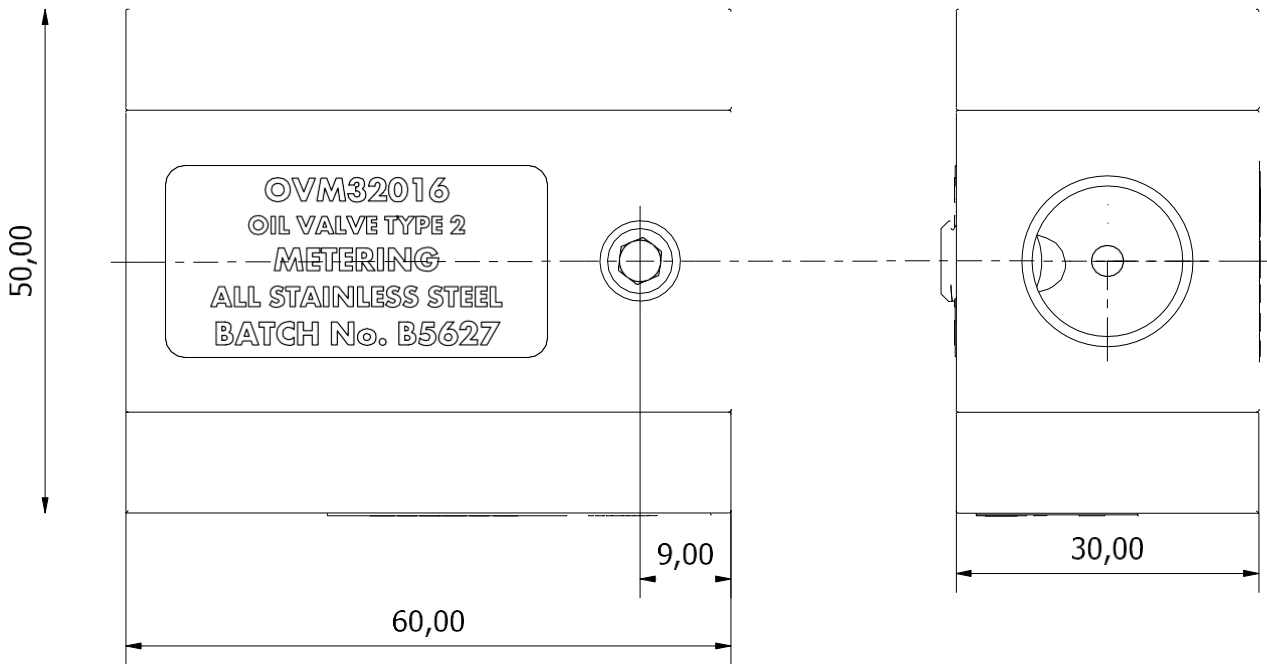
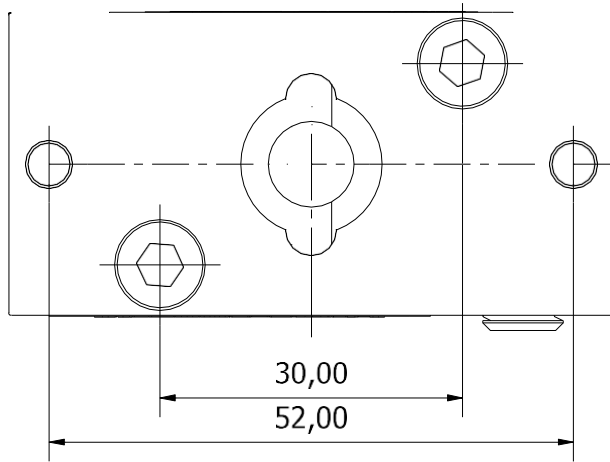

1.3.2. Large Oil Valves

Large Oil Control Valve



Large Oil Control Valve with Large Servomotor

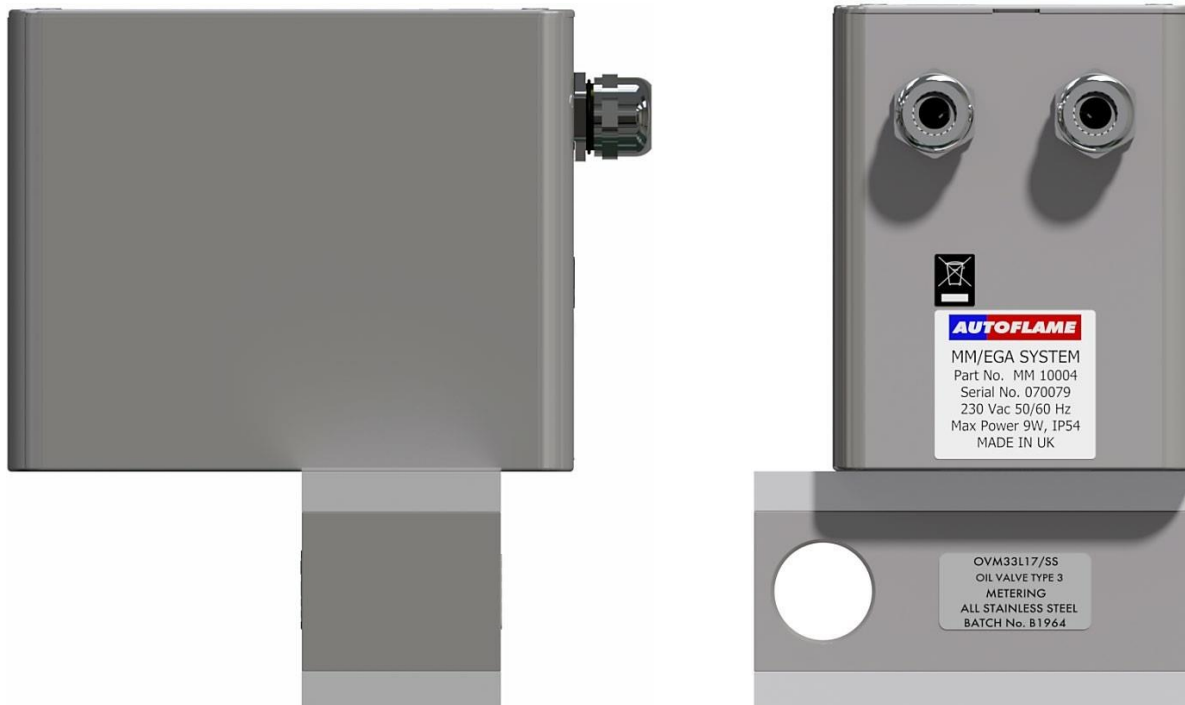

Large Oil Control Valve Dimensions

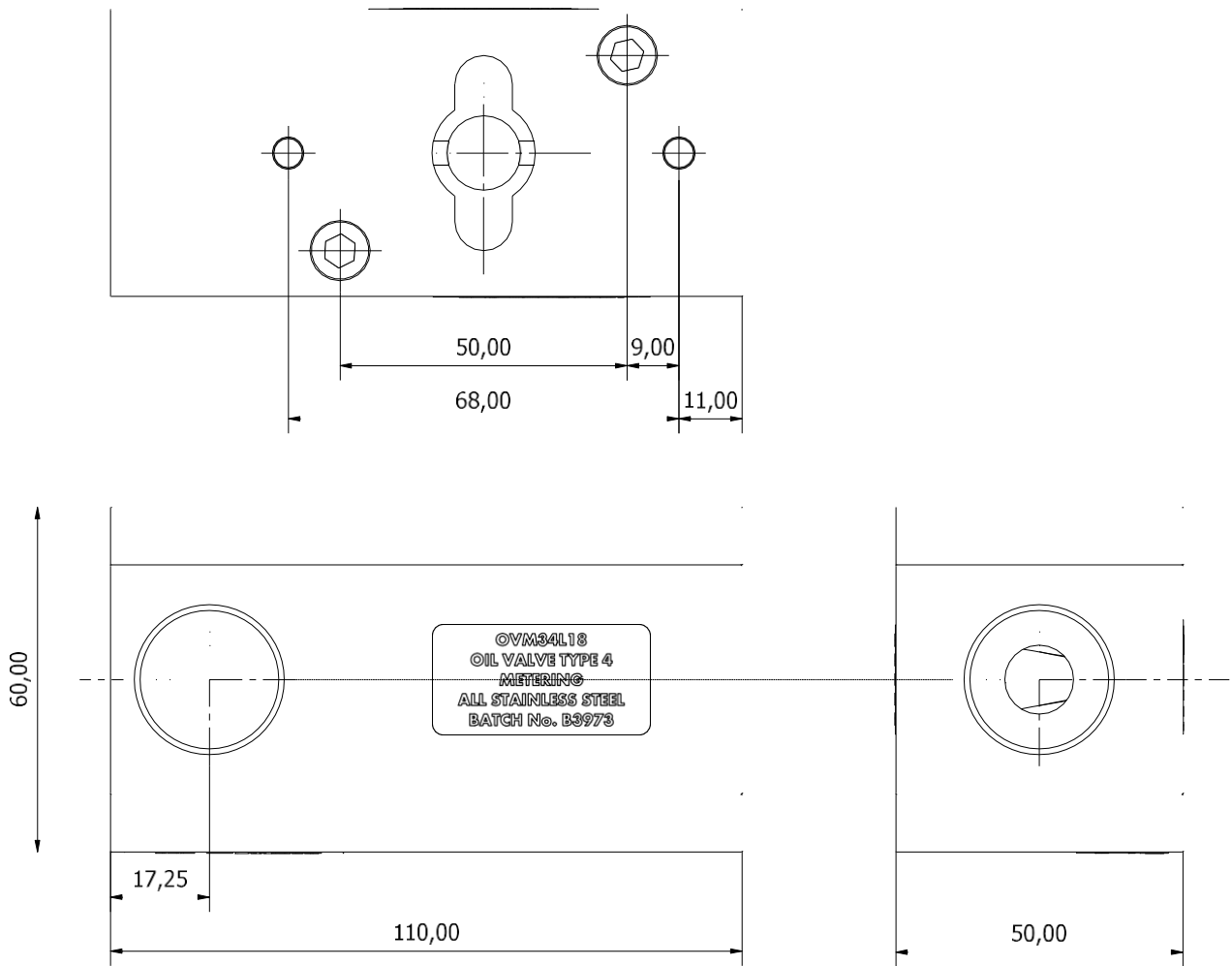

1.4. Oil Control Valves Flow

1.4.1. Small Spillback (Bypass) Oil Valve

A small spillback oil valve is configured as below:

- Turning the servomotor clockwise increases the flow at the nozzle.
- Turning the servomotor anti-clockwise decreases the flow at the nozzle.

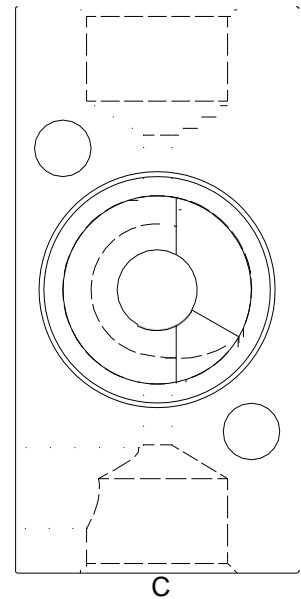
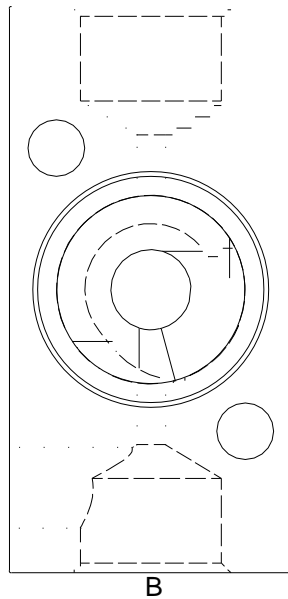
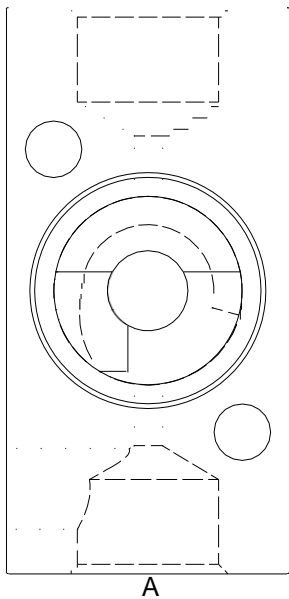
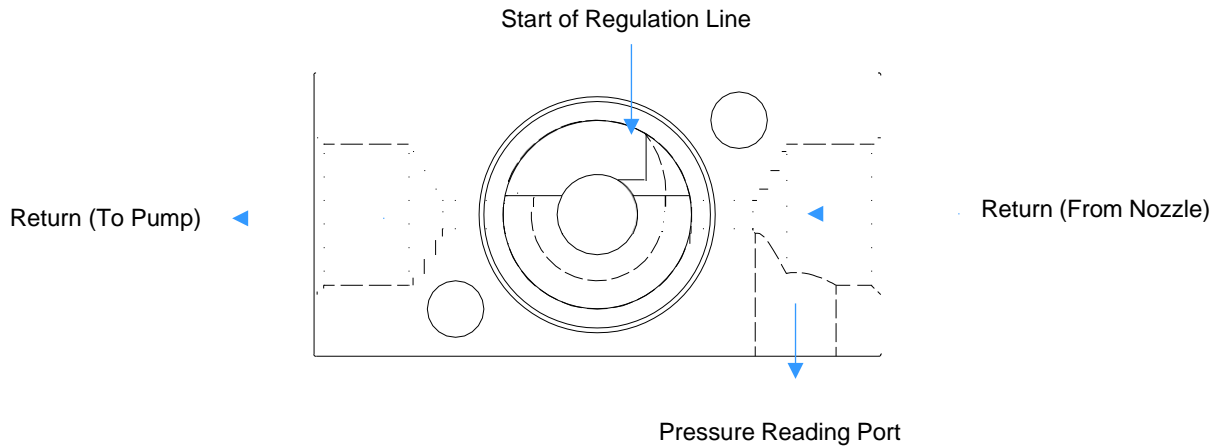

A	Fully closed position	Servomotor at 90°	Max. oil pressure at the nozzle Max. oil flow from the nozzle No oil return to pump/tank
B	45° open position		
C	Fully opened position	Servomotor at 0°	No oil pressure at the nozzle No oil flow from the nozzle All oil returns to pump/tank

1.4.2. Small Metering (Simplex) Oil Valve

A small metering oil valve is configured as below;

- Turning the servomotor clockwise increases the flow at the nozzle
- Turning the servomotor anti-clockwise decreases the flow at the nozzle

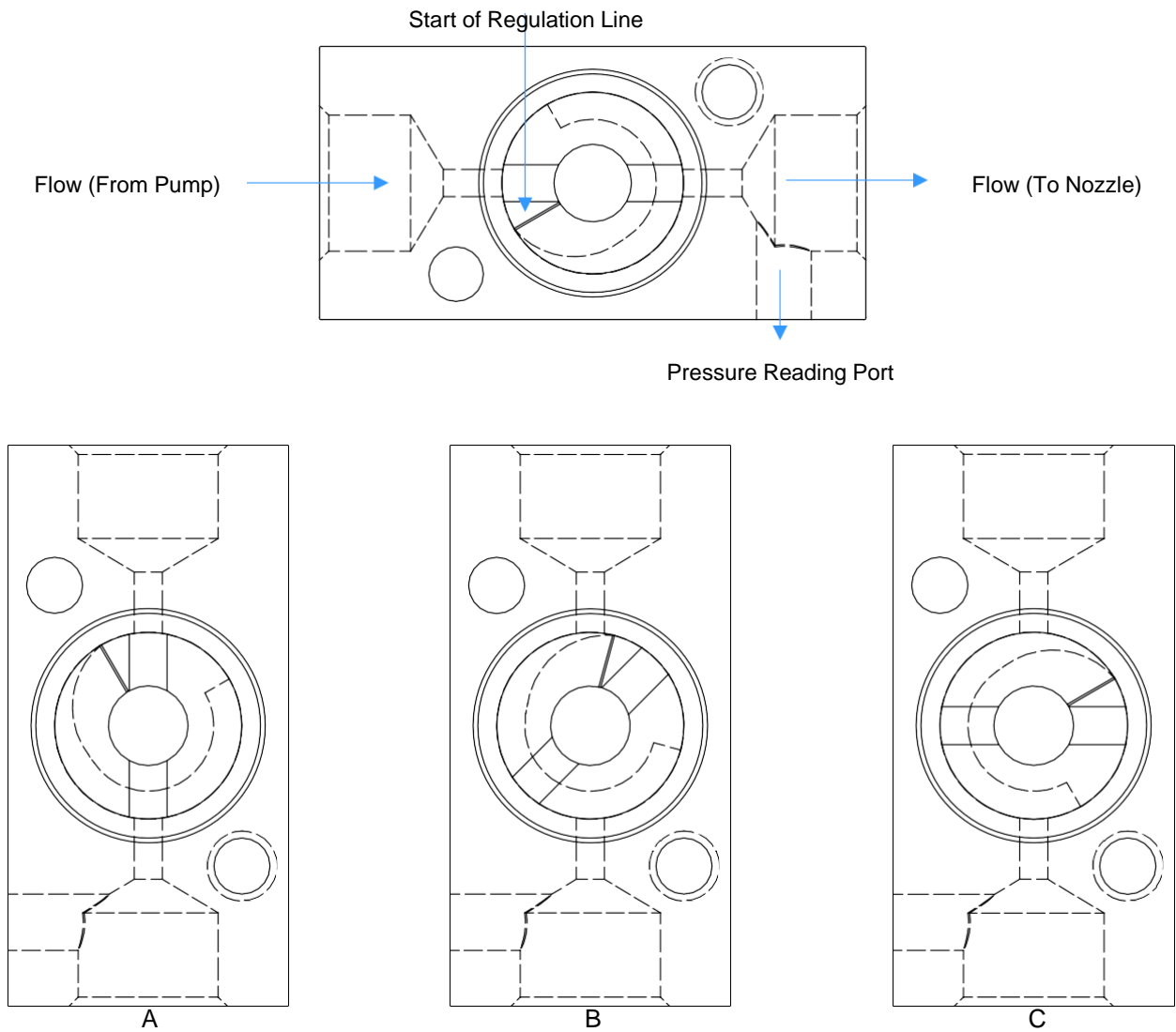

A	Fully closed position	Servomotor at 0°	No oil pressure at the nozzle No oil flow from the nozzle
B	45° open position		
C	Fully opened position	Servomotor at 90°	Max. oil pressure at the nozzle Max. oil flow from the nozzle

1.4.3. Large Spillback (Bypass) Oil Valve

A large metering oil valve is configured as below;

- Turning the servomotor clockwise increases the flow at the nozzle
- Turning the servomotor anti-clockwise decreases the flow at the nozzle

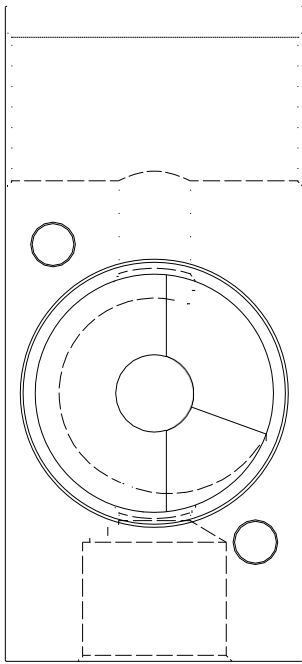
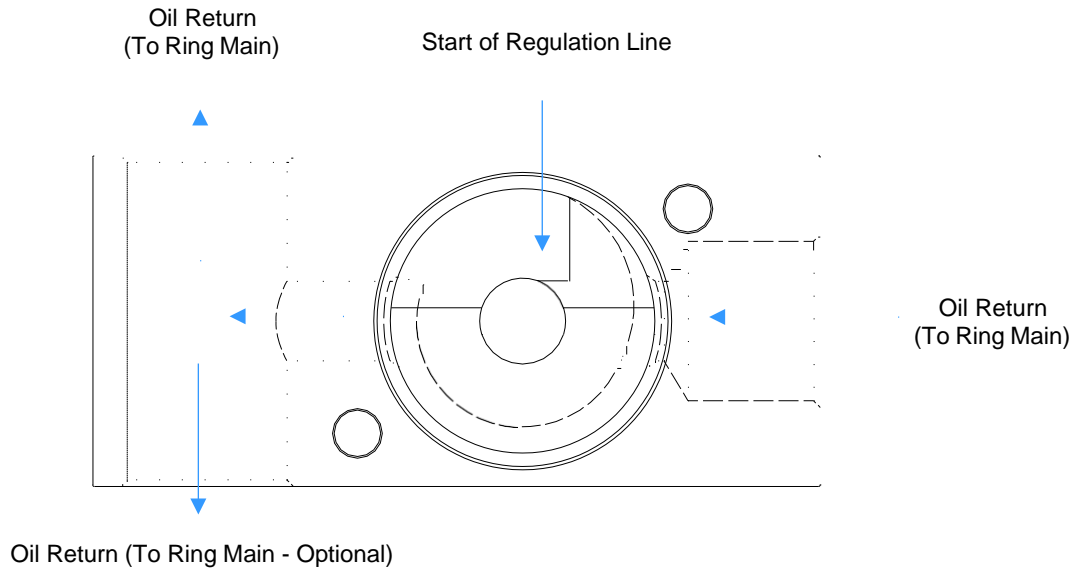

A

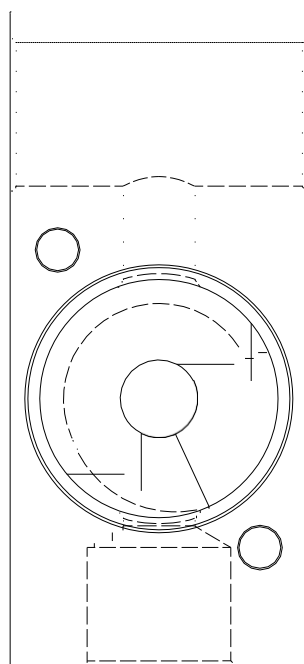

B

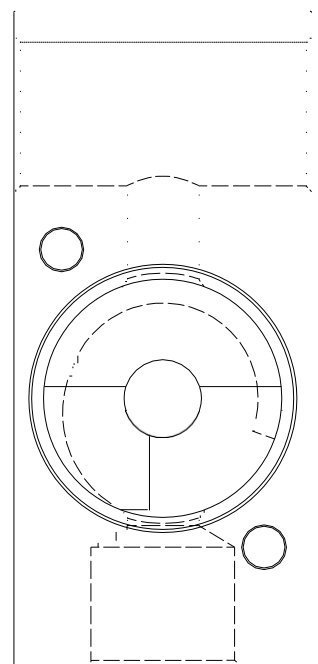

C

A	Fully open position	Servomotor at 0°	No oil pressure at the nozzle No oil flow from the nozzle All oil returns to pump/tank
B	45° open position		
C	Fully closed position	Servomotor at 90°	Max. oil pressure at the nozzle Max. oil flow from the nozzle No oil returns to pump/tank

1.4.4. Large Metering (Simplex) Oil Valve

A large metering oil valve is configured as below:

- turning the servomotor clockwise increases the flow at the nozzle
- turning the servomotor anti-clockwise decreases the flow at the nozzle

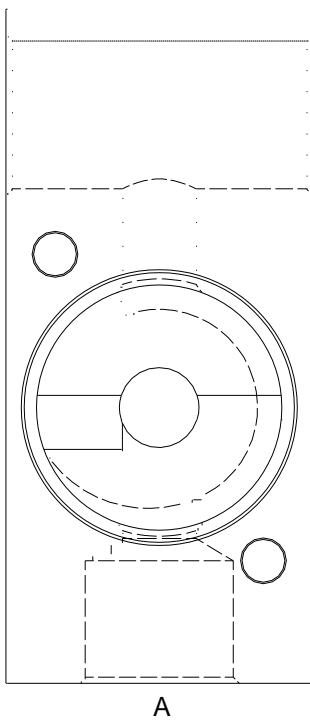
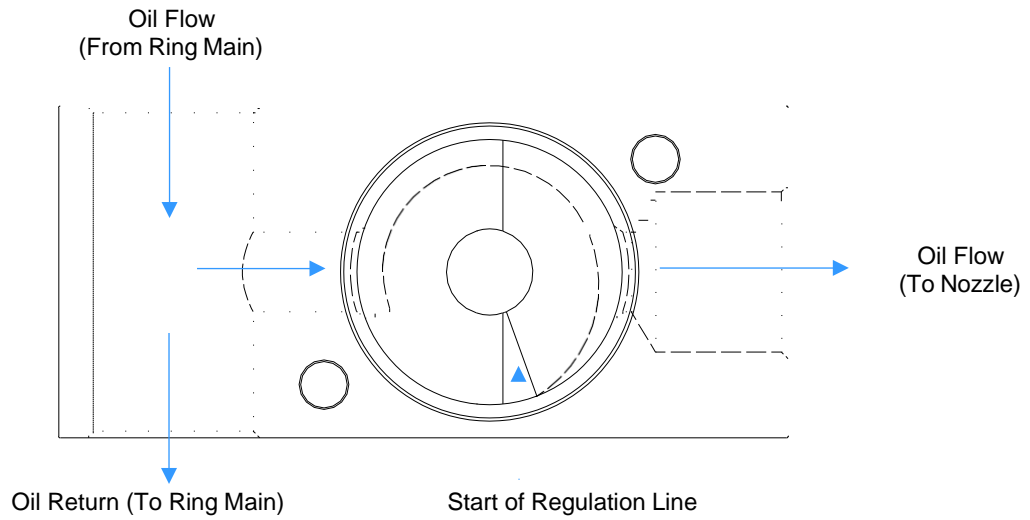

A

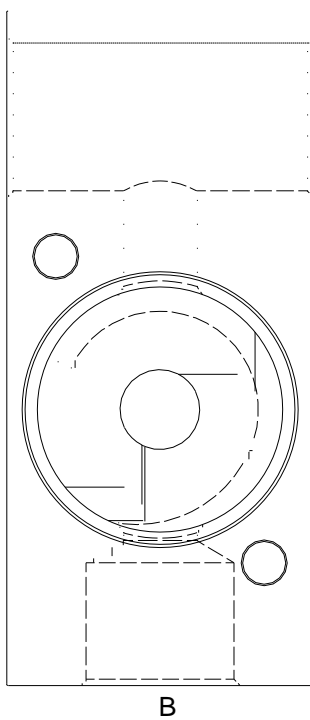

B

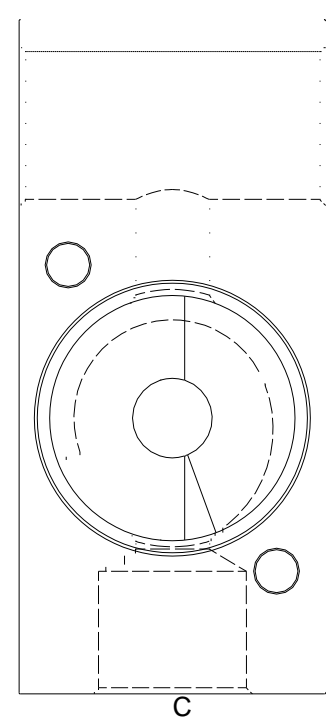

C

A	Fully open position	Servomotor at 90°	Max. oil pressure at the nozzle Max. oil flow to the nozzle
B	45° open position		
C	Fully closed position	Servomotor at 0°	No oil pressure at the nozzle No oil flow to the nozzle

1.5. Oil Valve Flow Characteristics

All flow pressure graphs for oil valves are using light distillate oil at 20°C with viscosity of 5 centistokes (cSt).

1.3.1. Type 1: OVS31015 Spillback (Bypass) / OVM31015 Metering (Simplex)

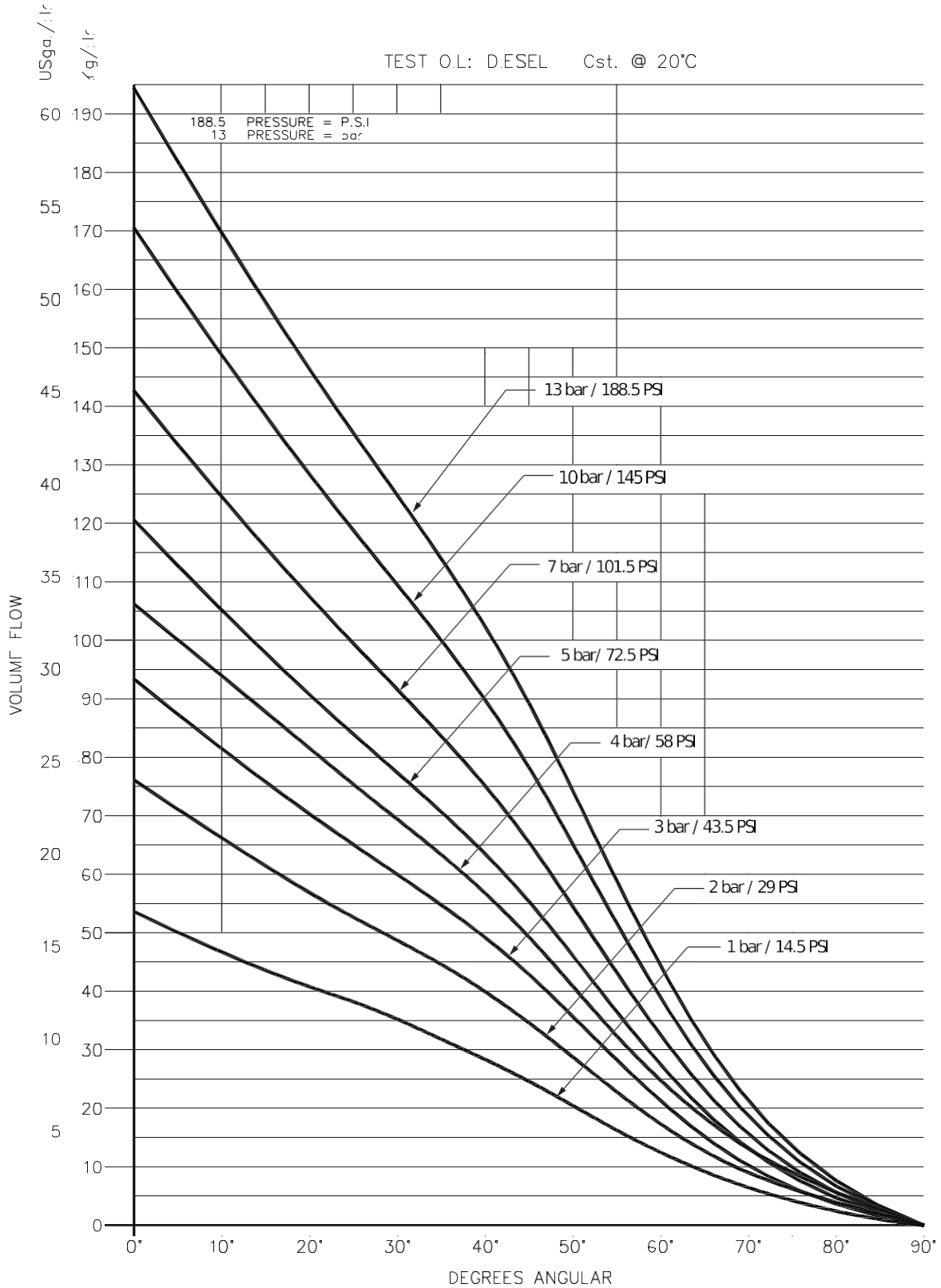

1.3.2. Type 2: OVS32016 Spillback (Bypass) / OVM32016 Metering (Simplex)

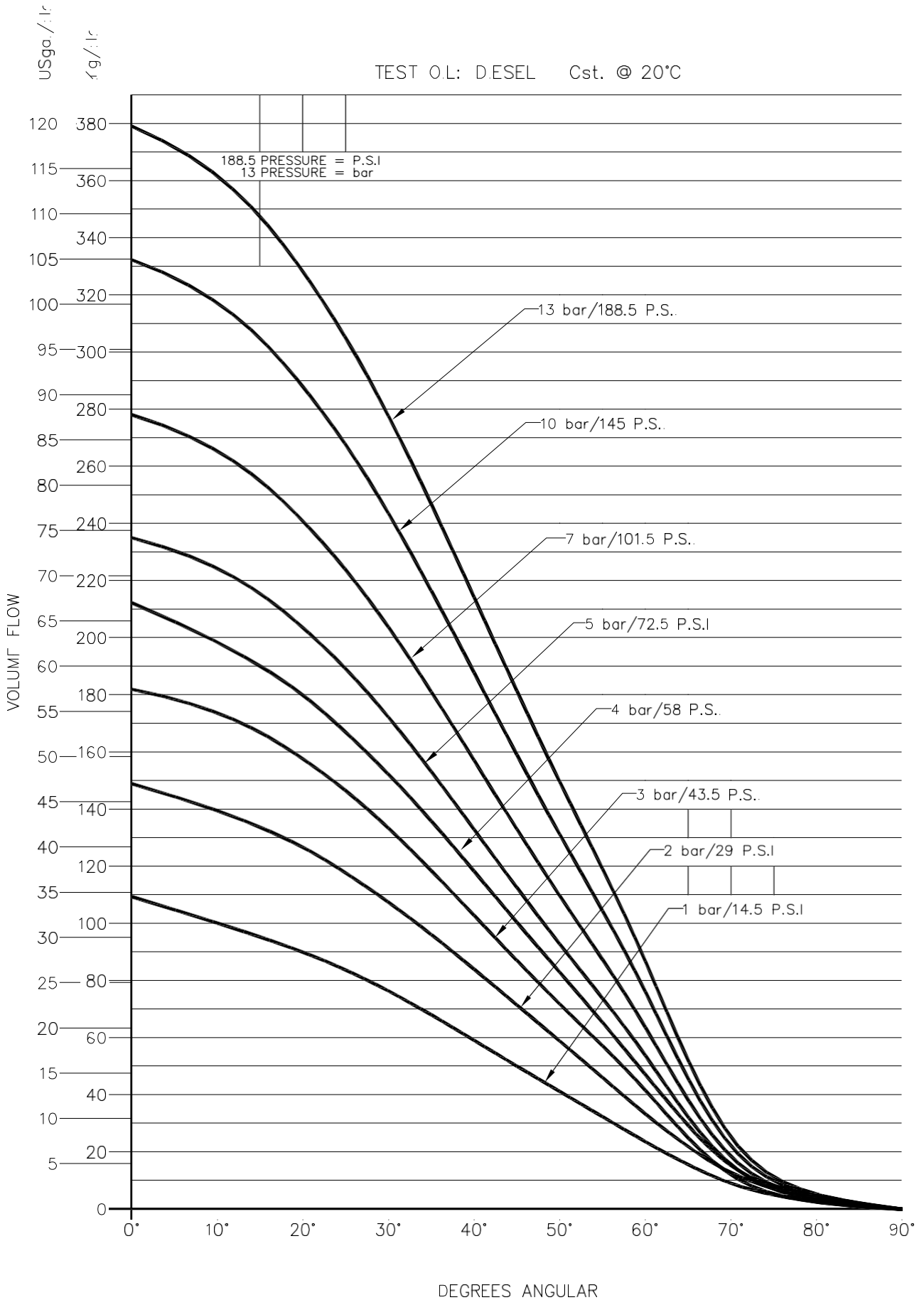

1.3.3. Type 4: OVS34L18 Spillback (Bypass) / OVM34L18 Metering (Simplex)

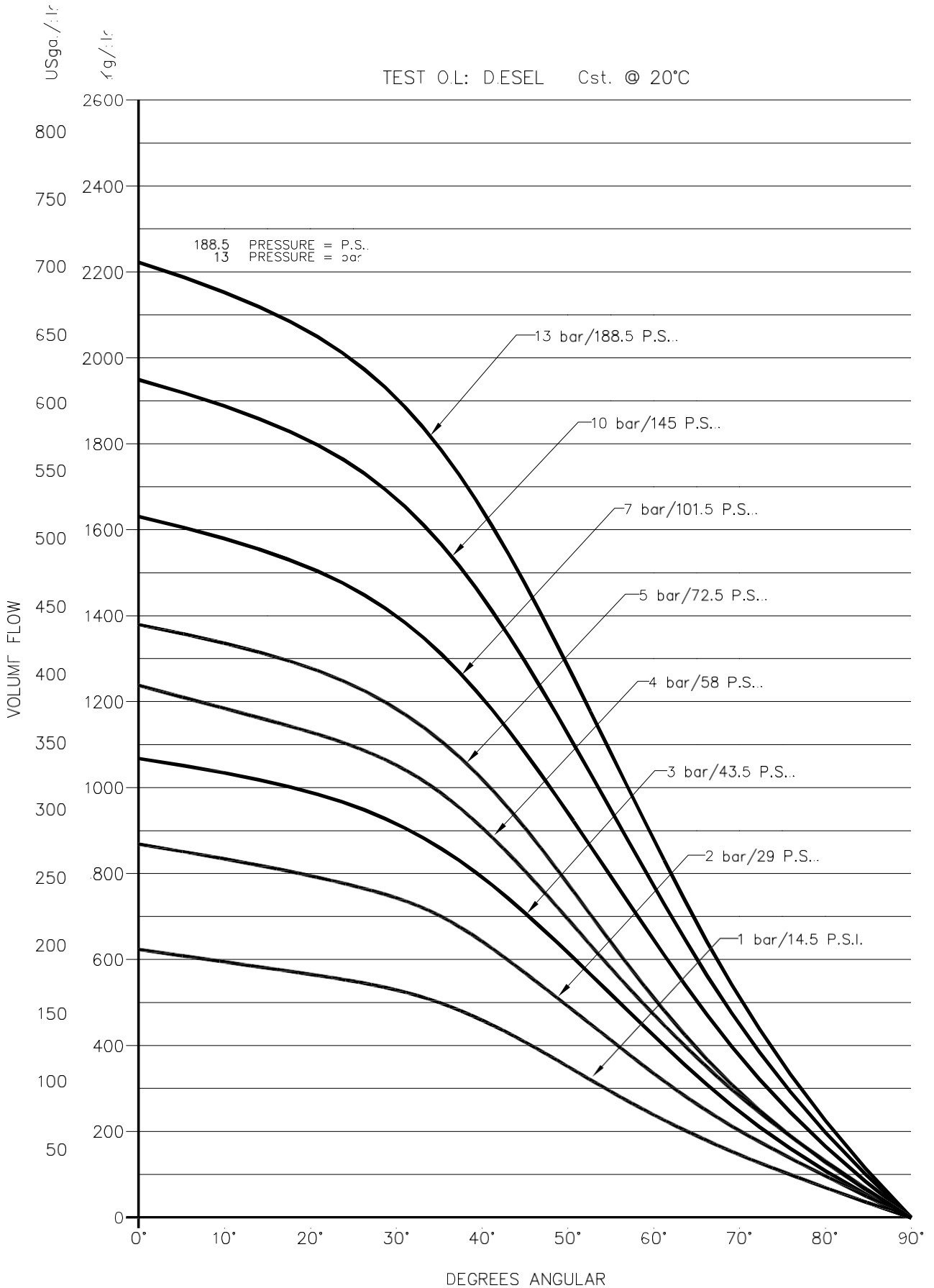

1.3.4. Type 5: OVS35019 Spillback (Bypass) / OVM35019 Metering (Simplex)

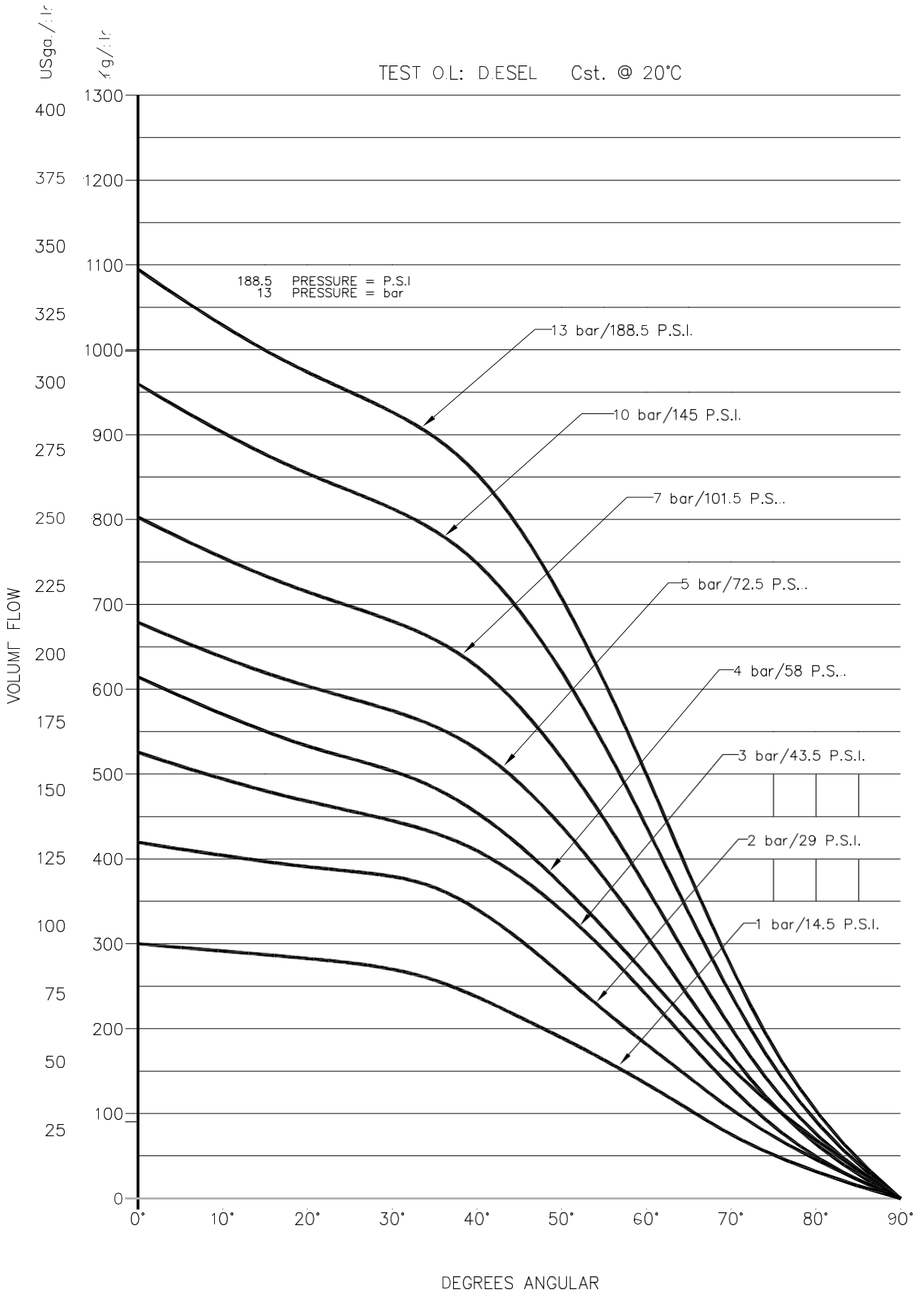

1.3.5. Type 6: OVM33L17 Metering (Simplex) / OVS33L17 Spillback (Bypass)

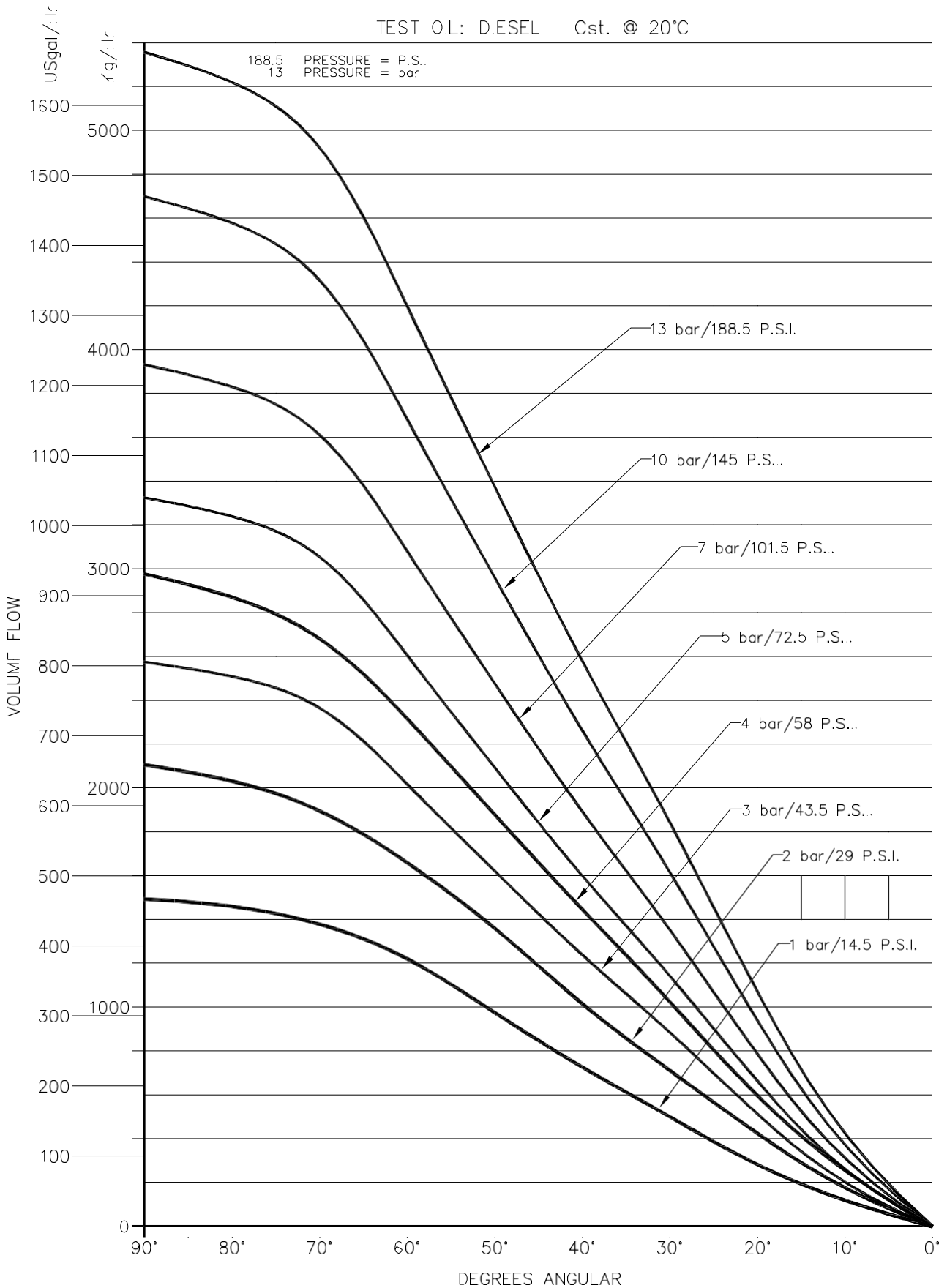

1.3.6. Type 6: OVM36020 Metering (Simplex) / OVS36020 Spillback (Bypass)

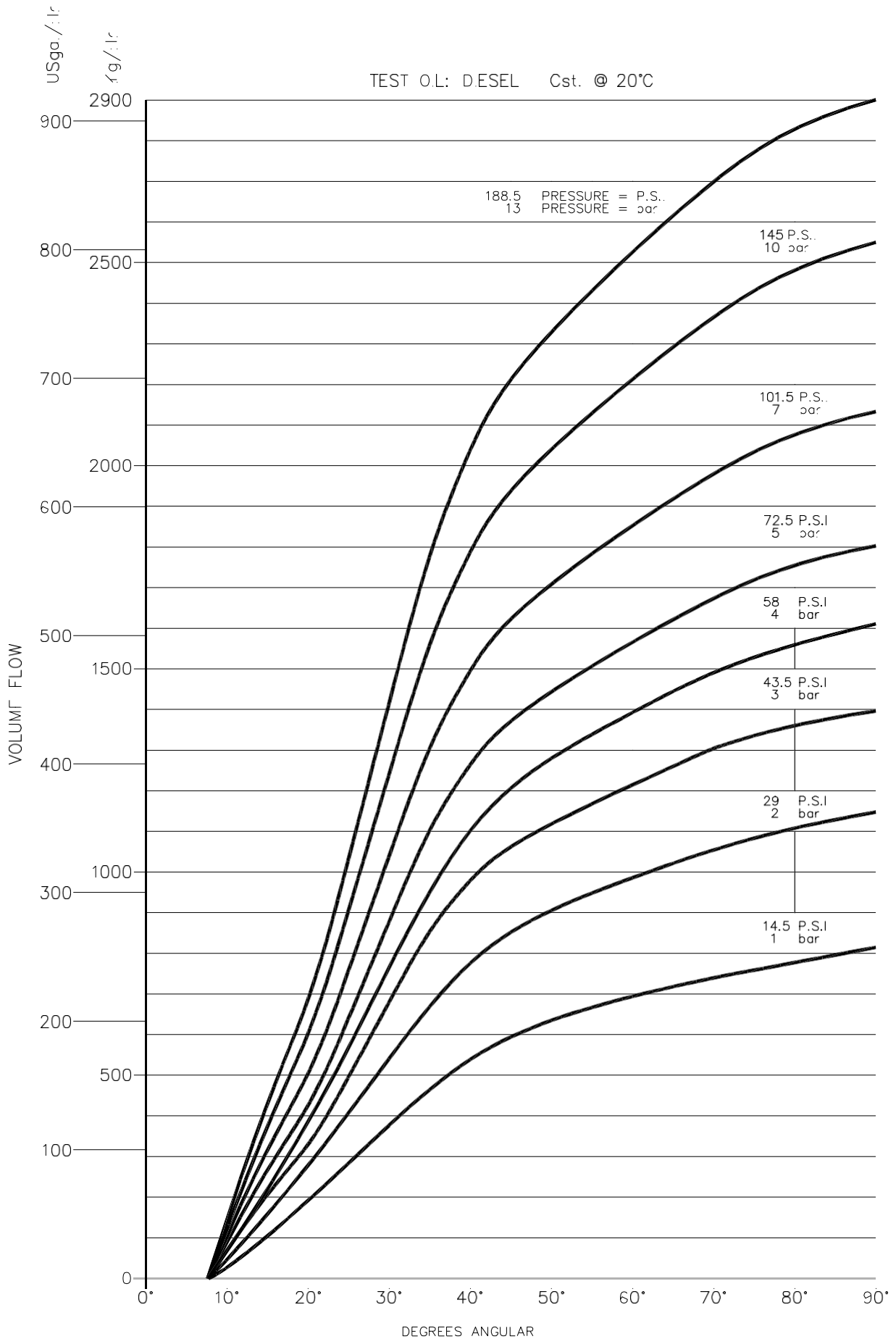

1.3.7. Type 8: OVM38022 Metering (Simplex) / OVS38022 Spillback (Bypass)

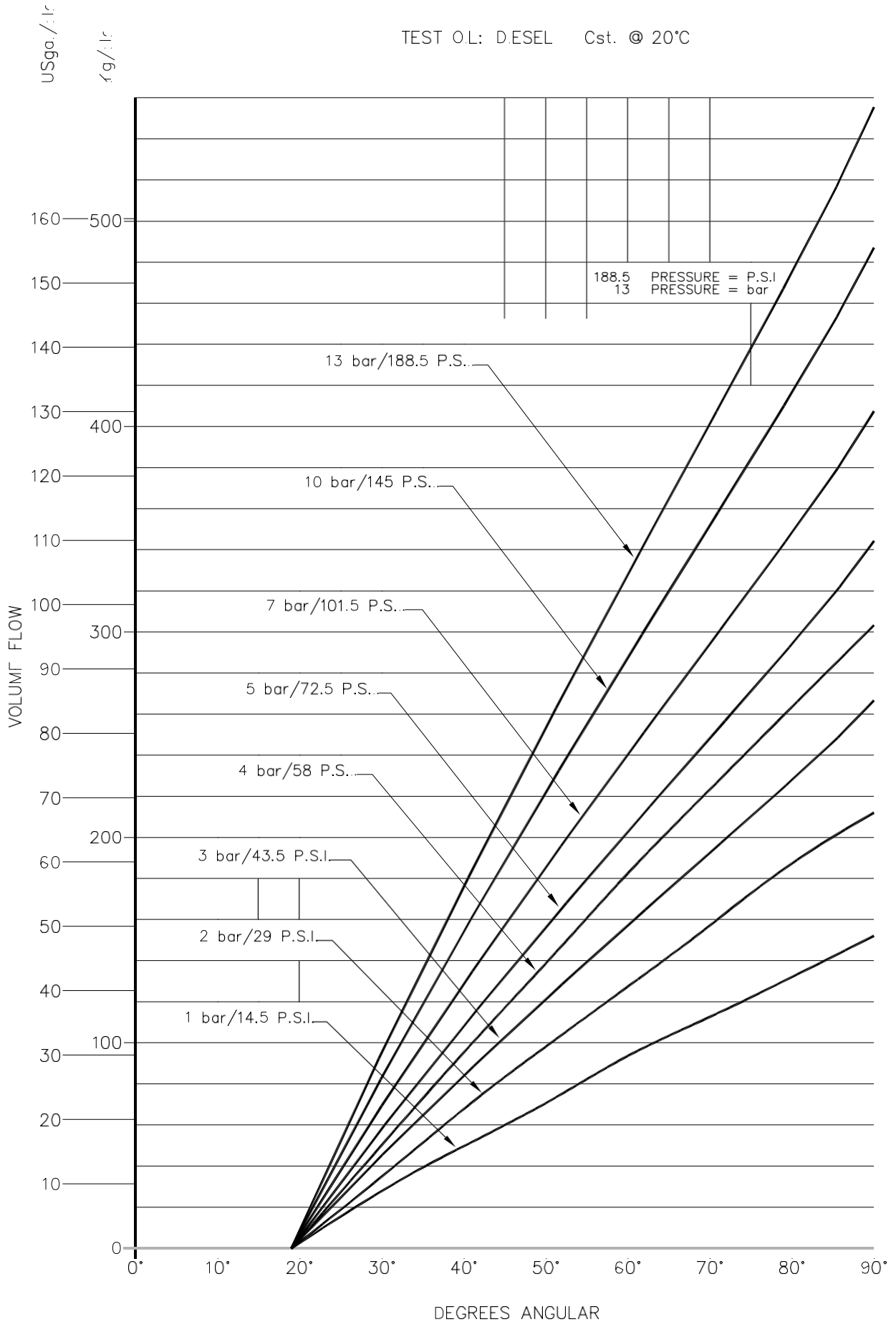

1.3.8. Type 9: OVS39023 Spillback (Bypass) / OVM39023 Metering (Simplex)

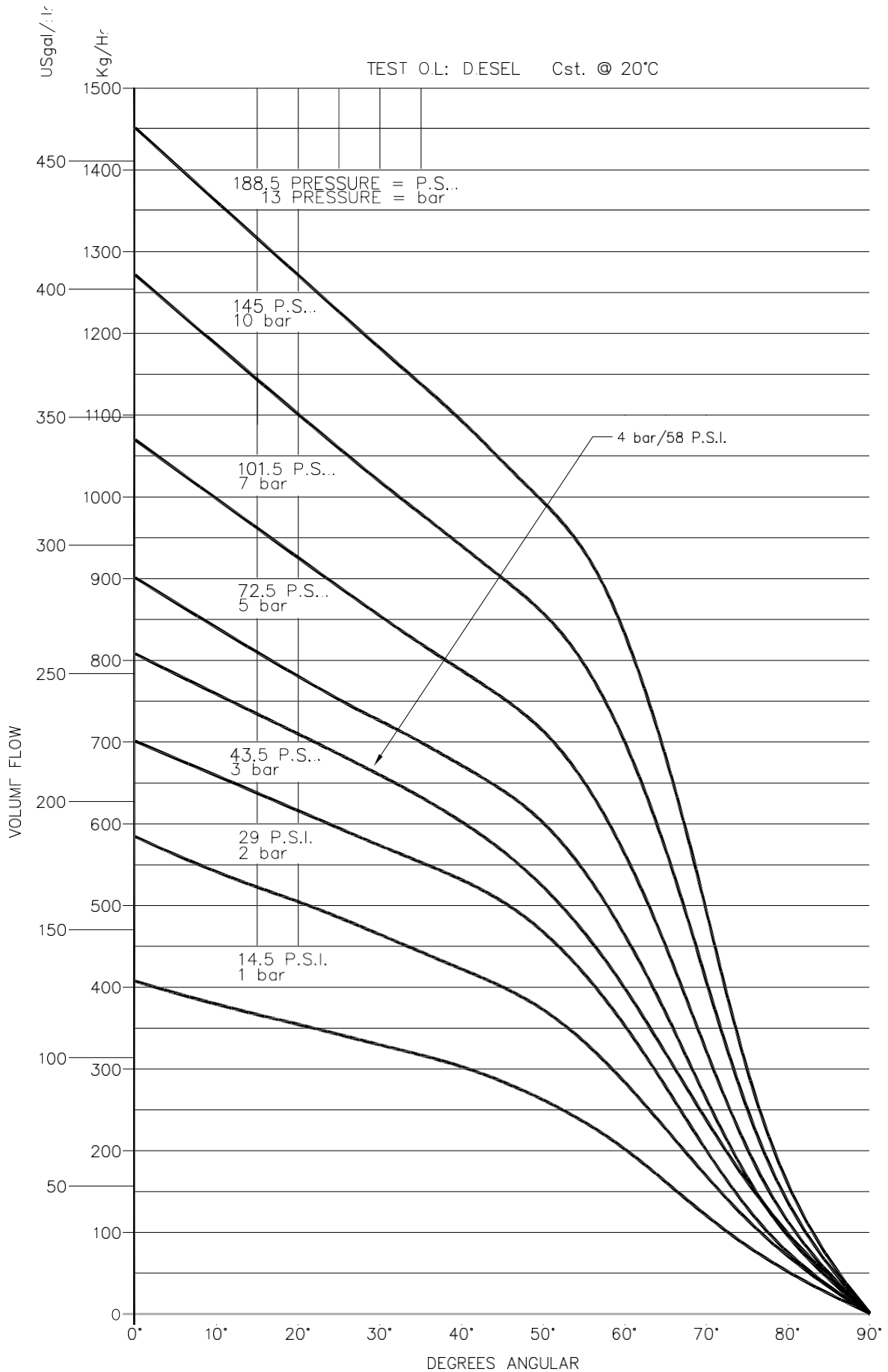

2. GAS CONTROL VALVES

Autoflame Gas Control Valves are butterfly type, they can be used for most gaseous fuels including, Natural Gas, Liquefied Petroleum Gas, Biogas, Hydrogen, Methane, Propane and many others.

Specification	
Valve body material	Option for Aluminium or 303 Stainless Steel
Control Disk Material	316 Stainless Steel
Shaft (spindle) material	316 Stainless Steel
Servo Mounting Plate material	Aluminium
Servomotor Coupling material	303 Stainless Steel
Max. pressure rating (threaded valves)	0.7 bar (10 PSI)
Max. pressure rating (flanged valves)	1.75 bar (25 PSI)
Max. operating temperature	90°C (194°F)
Min. operating temperature	-25°C (-13°F)

The following gas control valves are available as standard

Valve type	Servo required	Standard sizes available
Threaded BSP 1" to 3"	Small	1" to 3"
Threaded NPT 1" to 3"	Small	1" to 3"
Threaded BSP 4"	Large	4"
Threaded NPT 4"	Large	4"
Flanged PN16 30mm thick	Small	50 to 150mm
Flanged PN16 50mm thick	Large	50 to 150mm
Flanged ANSI 30mm thick	Small	2" to 6"
Flanged ANSI 50mm thick	Large	2" to 6"

All standard valves are available in Aluminium or Stainless-Steel body construction.

Other non-standard materials are available upon request, also larger valve sizes and different thicknesses are available, please contact Autoflame for more information.

2.1. Autoflame Gas Valve Flow Data

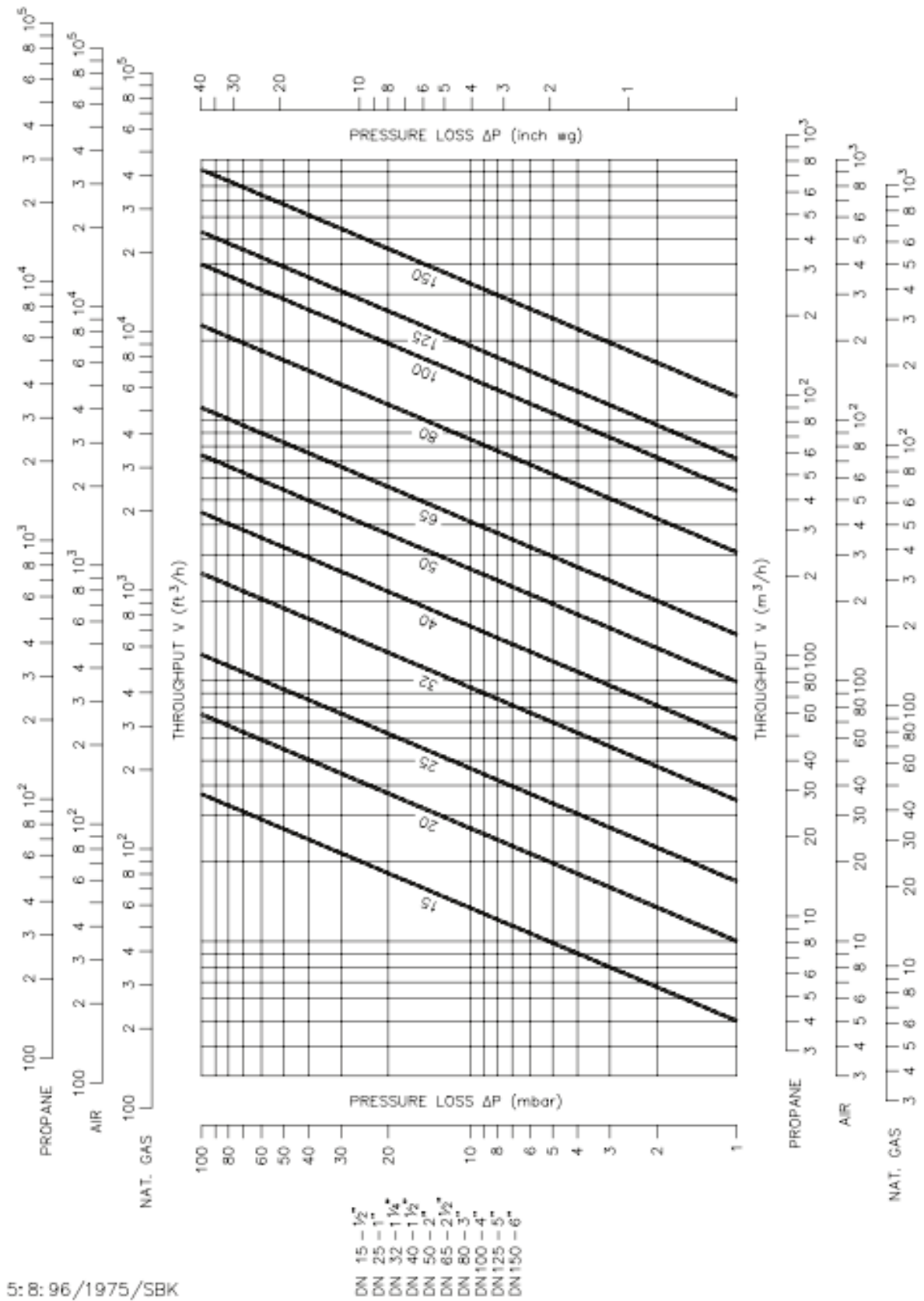

5: 8: 96/1975/SBK

2.2. Gas Control Valves - Threaded

Threaded gas valves are available in NPT (National Pipe Thread) or BSP (British Standard Pipe) parallel thread type. They are also available in Stainless Steel or Aluminium as standard.



The following thread gas control valves are available:

Valve Size	Thread Type	Part #	Material	Servomotor Size	
				Small	Large
25mm (1")	BSP	GV42521	Aluminium		
40mm (1.5")	BSP	GV44022	Aluminium		
50mm (2")	BSP	GV45023	Aluminium		
65mm (2.5")	BSP	GV46524	Aluminium		
80mm (3")	BSP	GV48025	Aluminium		
100mm (4")	BSP	GV410026	Aluminium		
25mm (1")	NPT	GV42521U	Aluminium		
40mm (1.5")	NPT	GV44022U	Aluminium		
50mm (2")	NPT	GV45023U	Aluminium		
65mm (2.5")	NPT	GV46524U	Aluminium		
80mm (3")	NPT	GV48025U	Aluminium		
100mm (4")	NPT	GV410026U	Aluminium		
25mm (1")	BSP	GV42521/SS	Stainless Steel		
40mm (1.5")	BSP	GV44022/SS	Stainless Steel		
50mm (2")	BSP	GV45023/SS	Stainless Steel		
65mm (2.5")	BSP	GV46524/SS	Stainless Steel		
80mm (3")	BSP	GV48025/SS	Stainless Steel		
100mm (4")	BSP	GV410026/SS	Stainless Steel		
25mm (1")	NPT	GV42521U/SS	Stainless Steel		
40mm (1.5")	NPT	GV44022U/SS	Stainless Steel		
50mm (2")	NPT	GV45023U/SS	Stainless Steel		
65mm (2.5")	NPT	GV46524U/SS	Stainless Steel		
80mm (3")	NPT	GV48025U/SS	Stainless Steel		
100mm (4")	NPT	GV410026U/SS	Stainless Steel		

External View



Dimensions

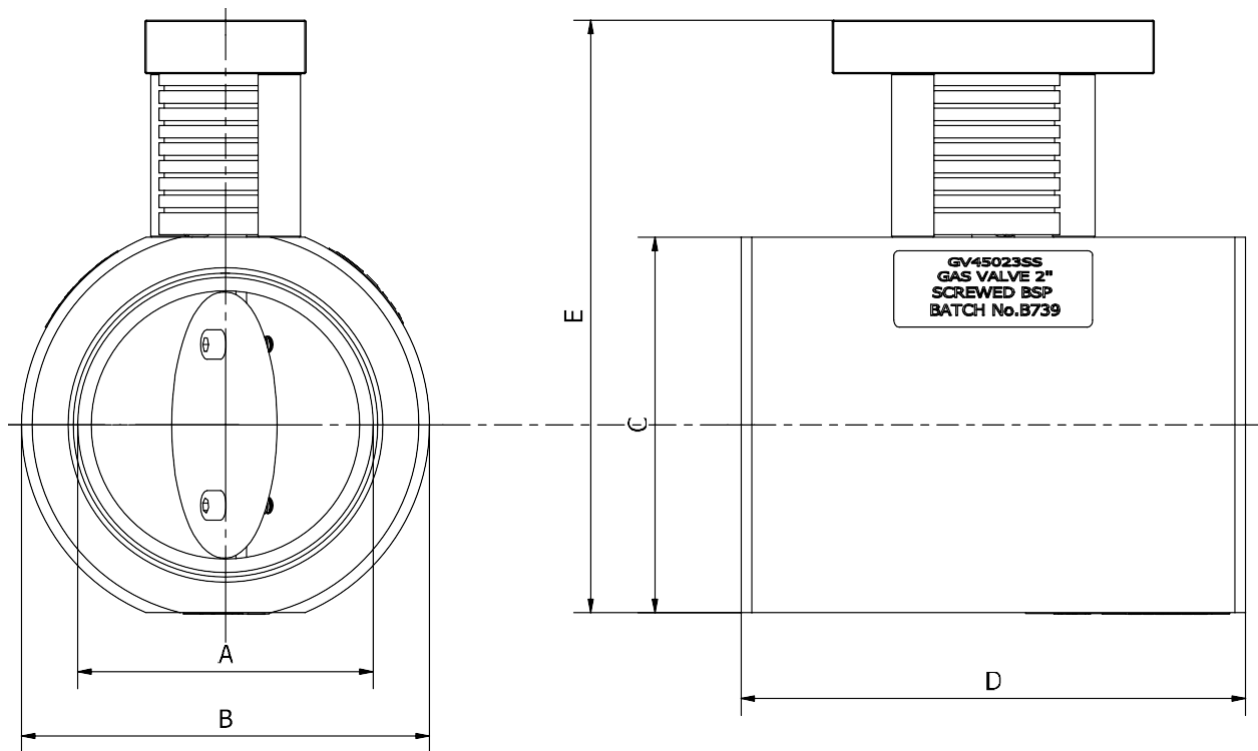

BSP

# Aluminium	# Stainless Steel	A	B	C	D
GV42521	GV42521/SS	25	54	45	94
GV44022	GV44022/SS	40	67	60	94
GV45023	GV45023/SS	50	76	70	94
GV46524	GV46524/SS	65	90	85	94
GV48025	GV48025/SS	80	105	100	94
GV410026	GV410026/SS	100			

NPT

# Aluminium	# Stainless Steel	A	B	C	D
GV42521U	GV42521U/SS	1"	2.125	1.75	3.7
GV44022U	GV44022U/SS	1.5"	2.64	2.375	3.7
GV45023U	GV45023U/SS	2"	3	2.75	3.7
GV46524U	GV46524U/SS	2.5"	3.5	3.35	3.7
GV48025U	GV48025U/SS	3"	4.125	4	3.7
GV410026U	GV410026U/SS	4"			

2.3. Gas Control Valves – Flanged (30mm Thickness)

These flanged gas control valves are available in PN16 or ANSI flange type. They are also available in Stainless Steel or Aluminium body construction as standard.

These valves require small servomotor (4Nm torque).



The following flanged gas control valves are available in 30mm (1.2") thickness:

Valve Size	Flange Type	Part #	Material
50mm (2")	PN16	GVF45028/30	Aluminium
65mm (2.5")		GVF46526/30	
80mm (3")		GVF48027/30	
100mm (4")		GVF410026/30	
125mm (5")		GVF12527/30	
150mm (6")		GVF415028/30	
50mm (2")	ANSI	GVF45028/30U	
65mm (2.5")		GVF46526/30U	
80mm (3")		GVF48027/30U	
100mm (4")		GVF410026/30U	
125mm (5")		GVF12527/30U	
150mm (6")		GVF415028/30U	
50mm (2")	PN16	GVF45028/30/SS	Stainless Steel
65mm (2.5")		GVF46526/30/SS	
80mm (3")		GVF48027/30/SS	
100mm (4")		GVF410026/30/SS	
125mm (5")		GVF12527/30/SS	
150mm (6")		GVF415028/30/SS	
50mm (2")	ANSI	GVF45028/30U/SS	
65mm (2.5")		GVF46526/30U/SS	
80mm (3")		GVF48027/30U/SS	
100mm (4")		GVF410026/30U/SS	
125mm (5")		GVF12527/30U/SS	
150mm (6")		GVF415028/30U/SS	

External view – with small standard servomotor

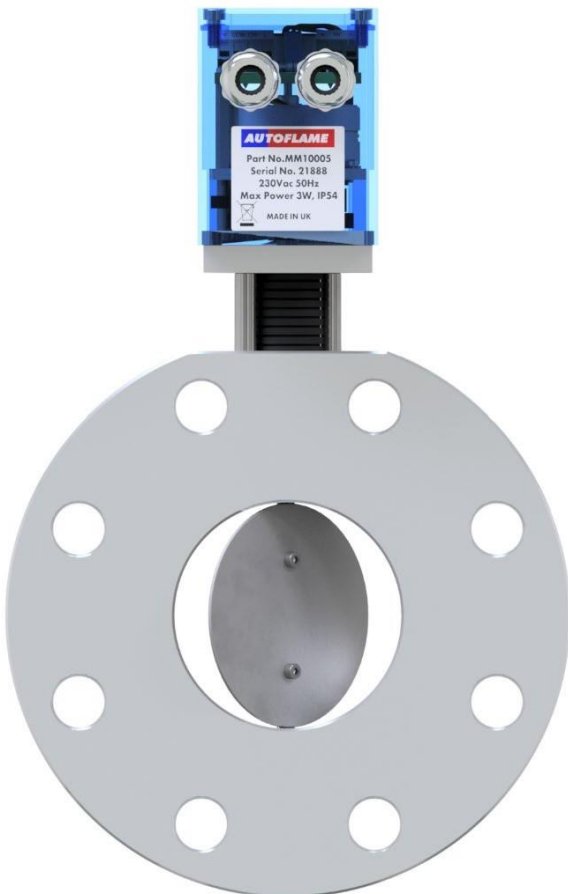

Dimensions

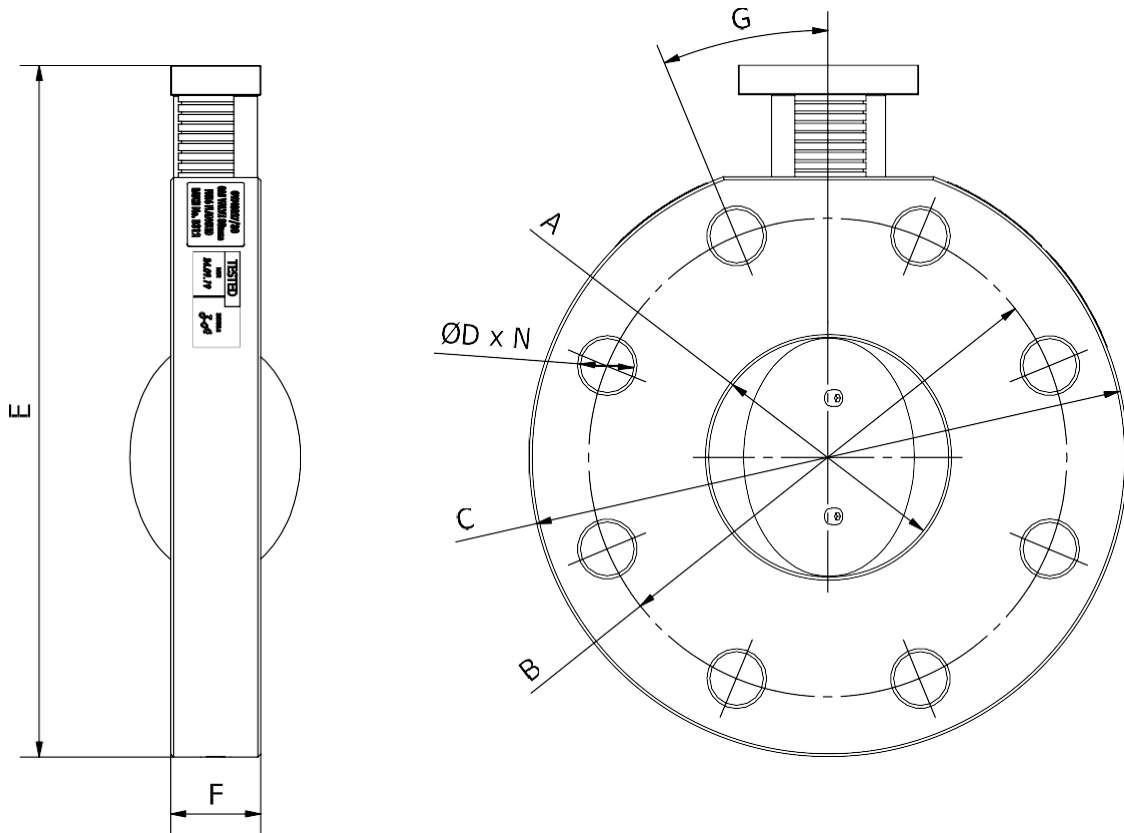

PN16 30mm

# Aluminium	# Stainless Steel	A	B	C	D	E	F	G	N
GVF45028/30	GVF45028/30/SS	50	125	165	M16	197	30	45°	4
GVF46526/30	GVF46526/30/SS	65	145	185	M16	219	30	45°	4
GVF48027/30	GVF48027/30/SS	80	160	200	M16	234	30	22.5°	8
GVF410026/30	GVF410026/30/SS	100	180	220	M16	254	30	22.5°	8
GVF12527/30	GVF12527/30/SS	125	210	250	M16	285	30	22.5°	8
GVF415028/30	GVF415028/30/SS	150	240	285	M20	321	30	22.5°	8

ANSI 30mm

Valve Part #	# Stainless Steel	A	B	C	D	E	F	G	N
GVF45028/30U	GVF45028/30U/SS	2"	4.75	6"	5/8"	8"	1.125"	45°	4
GVF46526/30U	GVF46526/30U/SS	2.5"	5.5	7"	5/8"	8.6"	1.125"	45°	4
GVF48027/30U	GVF48027/30U/SS	3"	6	7.5"	5/8"	9.375"	1.125"	22.5°	8
GVF410026/30U	GVF410026/30U/SS	4"	7.5	9"	5/8"	10"	1.125"	22.5°	8
GVF12527/30U	GVF12527/30U/SS	5"	8.5	10"	5/8"	1"	1.125"	22.5°	8
GVF415028/30U	GVF415028/30U/SS	6"	9.5	11"	3/4"	12.5"	1.125"	22.5°	8

2.4. Gas Control Valves – Flanged (50mm Thickness)

These flanged gas control valves are available in PN16 or ANSI flange type. They are also available in Stainless Steel or Aluminium body construction as standard.

These valves require large servomotor (25Nm torque)



The following flanged gas control valves are available in 30mm (1.2") thickness:

Valve Size	Flange Type	Part #	Material
50mm (2")	PN16	GVF45028/50	Aluminium
65mm (2.5")		GVF46526/50	
80mm (3")		GVF48027/50	
100mm (4")		GVF410026/50	
125mm (5")		GVF12527/50	
150mm (6")		GVF415028/50	
50mm (2")	ANSI	GVF45028/50U	
65mm (2.5")		GVF46526/50U	
80mm (3")		GVF48027/50U	
100mm (4")		GVF410026/50U	
125mm (5")		GVF12527/50U	
150mm (6")		GVF415028/50U	
50mm (2")	PN16	GVF45028/50/SS	Stainless Steel
65mm (2.5")		GVF46526/50/SS	
80mm (3")		GVF48027/50/SS	
100mm (4")		GVF410026/50/SS	
125mm (5")		GVF12527/50/SS	
150mm (6")		GVF415028/50/SS	
50mm (2")	ANSI	GVF45028/50U/SS	
65mm (2.5")		GVF46526/50U/SS	
80mm (3")		GVF48027/50U/SS	
100mm (4")		GVF410026/50U/SS	
125mm (5")		GVF12527/50U/SS	
150mm (6")		GVF415028/50U/SS	

External view – with small standard servomotor



Dimensions

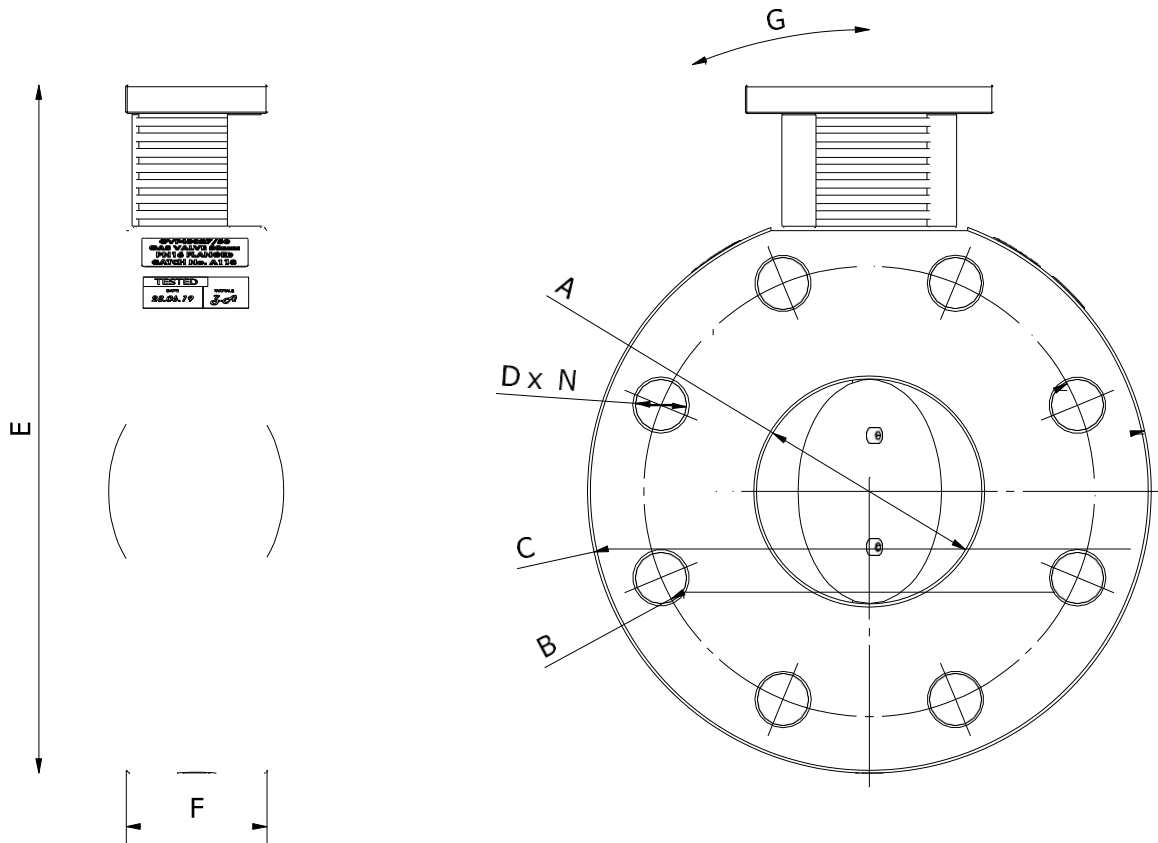

PN16 50mm

# Aluminium	# Stainless Steel	A	B	C	D	E	F	G	N
GVF45028/50	GVF45028/50/SS	50	125	165	M16	197	30	45°	4
GVF46526/50	GVF46526/50/SS	65	145	185	M16	219	30	45°	4
GVF48027/50	GVF48027/50/SS	80	160	200	M16	234	30	22.5°	8
GVF410026/50	GVF410026/50/SS	100	180	220	M16	254	30	22.5°	8
GVF12527/50	GVF12527/50/SS	125	210	250	M16	285	30	22.5°	8
GVF415028/50	GVF415028/50/SS	150	240	285	M20	321	30	22.5°	8

ANSI 50mm

# Aluminium	# Stainless Steel	A	B	C	D	E	F	G	N
GVF45028/50U	GVF45028/50U/SS	50	4.75	165	M16	197	30	45°	4
GVF46526/50U	GVF46526/50U/SS	65	5.5	185	M16	219	30	45°	4
GVF48027/50U	GVF48027/50U/SS	80	6	200	M16	234	30	22.5°	8
GVF410026/50U	GVF410026/50U/SS	100	7.5	220	M16	254	30	22.5°	8
GVF12527/50U	GVF12527/50U/SS	125	8.5	250	M16	285	30	22.5°	8
GVF415028/50U	GVF415028/50U/SS	150	9.5	285	M20	321	30	22.5°	8

3. GAS & OIL VALVES WITH SINGLE SERVMOTOR CONTROL

On dual fuel applications (oil and gas), it is possible to control both the gas and oil control valves using single servomotor by installing the valves in “piggyback” arrangement. The bottom aluminium plate of the oil valve must be removed for assembly with the gas control valve.

This arrangement is not possible with Fuel Change on the Fly (COF) operation mode.



Exploded View



4. FGR / DRAFT CONTROL VALVES

Flow Gas Recirculation (FGR) works by allowing part of the boiler's exhaust gases to be taken from the stack and mixed with the combustion gases in the burner for the purpose of reducing NOx levels in the exhaust gas.

Autoflame FGR valves are butterfly type, they are CNC machined for precision control of the amount of FGR, they have an operating temperatures of up to 250°C. Autoflame FGR valves can also be used for Draft Control applications.

Specification	
Valve body material	Aluminium 303 Stainless Steel
Control Disk Material	316 Stainless Steel
Shaft (spindle) material	316 Stainless Steel
Servo Mounting Plate material	Aluminium
Servomotor Coupling material	303 Stainless Steel
Max. pressure rating	1.75 bar (25 PSI)
Max. operating temperature	250°C (482°F)
Min. operating temperature	-10°C (14°F)
Lubrication	2 greasing nipple points Use Rocol Sapphire Extreme® for lubrication

The following FGR control valves are available as standard:

Valve type	Servo required	Standard sizes available
Flanged PN16 50mm thick	Large	100 to 300mm
Flanged ANSI 50mm thick	Large	4" to 12"

Other non-standard materials are available upon request, also larger (up to 36") / smaller valve sizes and different thicknesses are available, please contact Autoflame for more information.

All standard FGR valves are available in Aluminium or Stainless-Steel body construction.

Part Number	Flange Type	Valve Size	Thickness	Valve Material	
FGR 410026/50	PN16	100mm (4")	50mm (2")	Aluminium	
FGR 415028/50		150mm (6")			
FGR 420029/50		200mm (8")			
FGR 425030/50		250mm (10")			
FGR 430031/50		300mm (12")			
FGR 410026/50U	ANSI 150lb	100mm (4")		50mm (2")	Aluminium
FGR 415028/50U		150mm (6")			
FGR 420029/50U		200mm (8")			
FGR 425030/50U		250mm (10")			
FGR 430031/50U		300mm (12")			
FGR 410026/50/SS	PN16	100mm (4")	50mm (2")		Stainless-Steel
FGR 415028/50/SS		150mm (6")			
FGR 420029/50/SS		200mm (8")			
FGR 425030/50/SS		250mm (10")			
FGR 430031/50/SS		300mm (12")			
FGR 410026/50U/SS	ANSI 150lb	100mm (4")		50mm (2")	Stainless-Steel
FGR 415028/50U/SS		150mm (6")			
FGR 420029/50U/SS		200mm (8")			
FGR 425030/50U/SS		250mm (10")			
FGR 430031/50U/SS		300mm (12")			

FGR Valve and Large Servomotor Assembly





Dimension

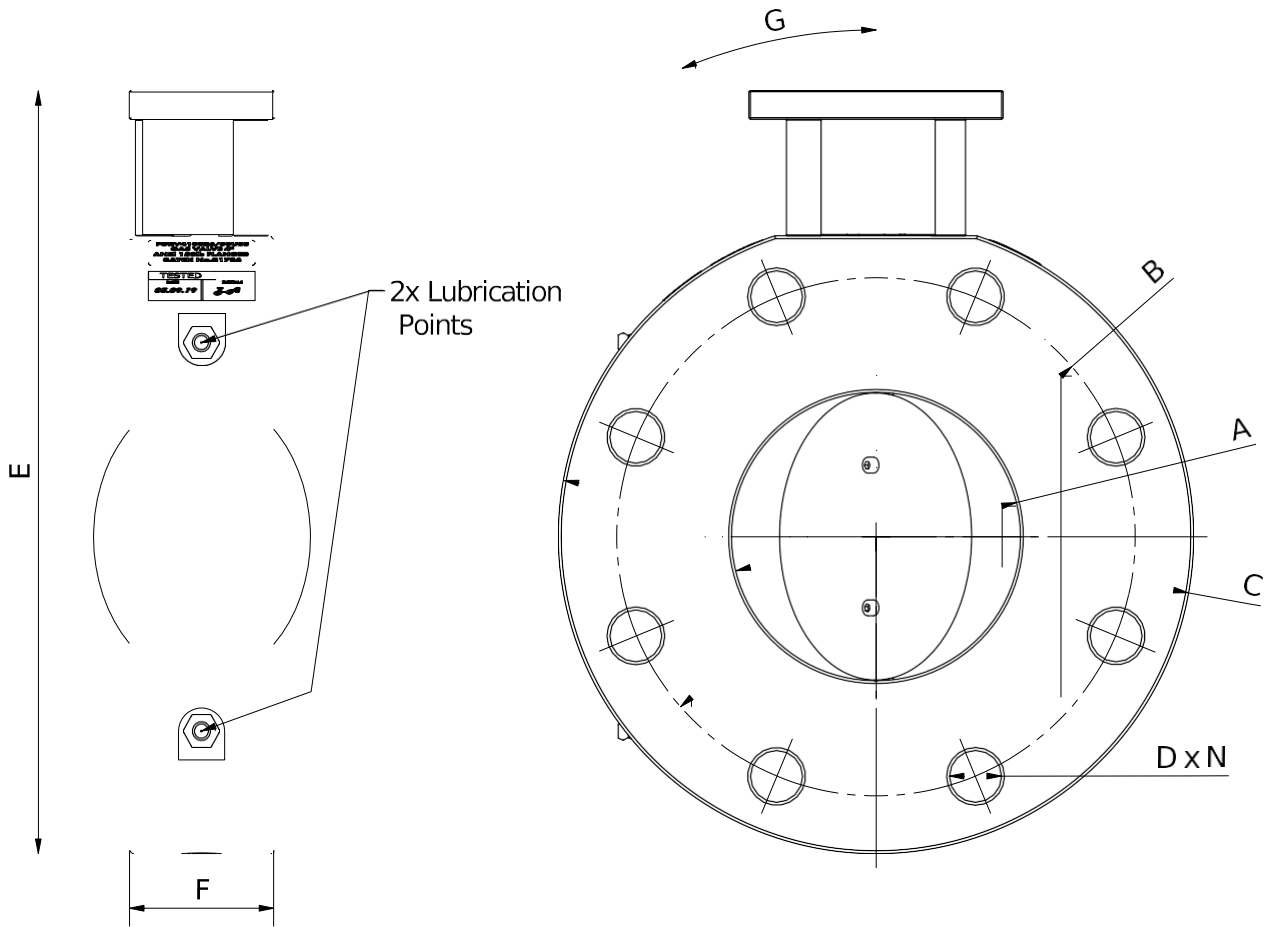

PN16 (dimensions in mm)

# Aluminium	# Stainless Steel	A	B	C	D	E	F	G	N
FGR 410026/50	FGR 410026/50/SS	100	180	220	M16	254	50	22.5°	8
FGR 415028/50	FGR 415028/50/SS	150	240	285	M20	321	50	22.5°	8
FGR 420029/50	FGR 420029/50/SS	200	295	340	M20	376	50	15°	12
FGR 425030/50	FGR 425030/50/SS	250	355	405	M24	441	50	15°	12
FGR 430031/50	FGR 430031/50/SS	300	410	460	M24	496	50	15°	12

ANSI (dimensions in inch)

# Aluminium	# Stainless Steel	A	B	C	D	E	F	G	N
FGR 410026/50U	FGR 410026/50U/SS	4	7 ½	9	5/8	8.92	2	22.5°	8
FGR 415028/50U	FGR 415028/50U/SS	6	9 ½	11	¾	10.92	2	22.5°	8
FGR 420029/50U	FGR 420029/50U/SS	8	11 ¾	13 ½	¾	13.17	2	15°	12
FGR 425030/50U	FGR 425030/50U/SS	10	14 ¼	16	7/8	15.67	2	15°	12
FGR 430031/50U	FGR 430031/50U/SS	12	17	19	7/8	18.42	2	15°	12

5. WATER VALVES

Autoflame water valves are ball-type valves featuring a floating ball design for low torque and increased cycle life. As standard large size valves feature trunnion-type ball support. These rugged ball valves are heavy-duty, ideal for industrial applications.

Autoflame water valves are universal for Feedwater Control, Top Blowdown (TBD) and Bottom Blowdown (BBD) functions.

The table below lists the standard Autoflame water valves part numbers, types, sizes and servomotor size required to drive each valve.

Valve Type	Valve Size	Part #	Servomotor Size		
			Large	UNIC05	UNIC10
Threaded Feed Water BSP/ NPT	15mm (1/2")	WLCVO15			
	20mm (3/4")	WLCVO20			
	25mm (1")	WLCVO25/FL			
Flanged Feed Water PN40	40mm (1 1/2")	WLCVO40/FL			
	50mm (2")	WLCVO50/FL			
	25mm (1")	WLCVO25/FLU			
Flanged Feed Water ANSI 300lb	40mm (1 1/2")	WLCVO40/FLU			
	50mm (2")	WLCVO50/FLU			
	15mm (1/2")	TDS70001/M15			
Threaded TDS BSP/ NPT	20mm (3/4")	TDS70001/M20			
	25mm (1")	BBV025FL			
	40mm (1 1/2")	BBV040FL			
Flanged BBD PN16/40	50mm (2")	BBV050FL			
	25mm (1")	BBV025FLU			
	40mm (1 1/2")	BBV040FLU			
Flanged BBD ANSI 300lb	50mm (2")	BBV050FLU			

General Specifications	
Max. operating pressure	29 Bar (425 PSI)
Max. operating temperature	235°C (455°F)
Valve Material	Stainless Steel, Carbon Steel & Special Alloys

Non-standard water valves with different sizes and specifications are also available upon request. Please contact Autoflame with your requirements.

5.1. Threaded Water Valve



Threaded Water Valve – Dimensions

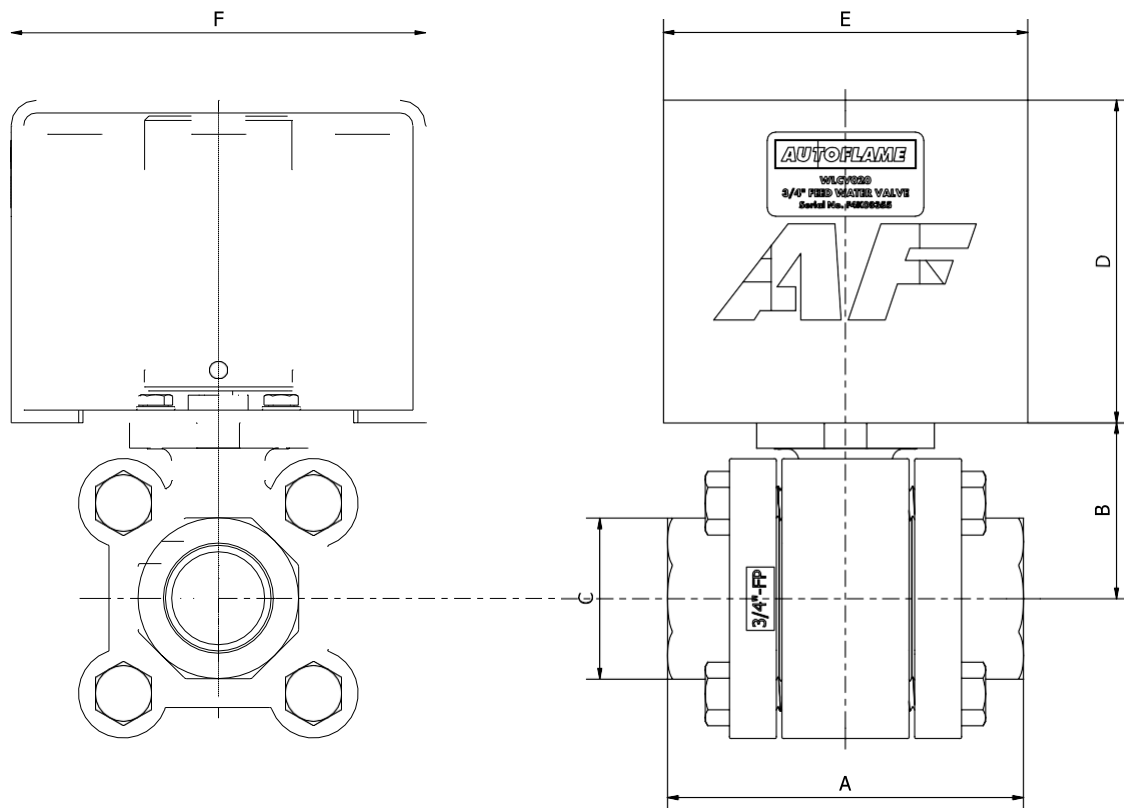

Dimensions: mm

Part #	Size	A	B	C	D	E	F
WLCVO15	15	76.0	36.9	32.0	76.5	86.0	98.5
WLCVO20	20	84.0	41.5	38.0	76.5	86.0	98.5

Dimensions: inch

Part #	Size	A	B	C	D	E	F
WLCVO15	0.5	2.99	1.26	1.26	3.01	3.39	3.88
WLCVO20	0.75	3.31	1.63	1.50	3.01	3.39	3.88

5.2. Flanged Water Valve



Flanged Water Valve – Dimensions

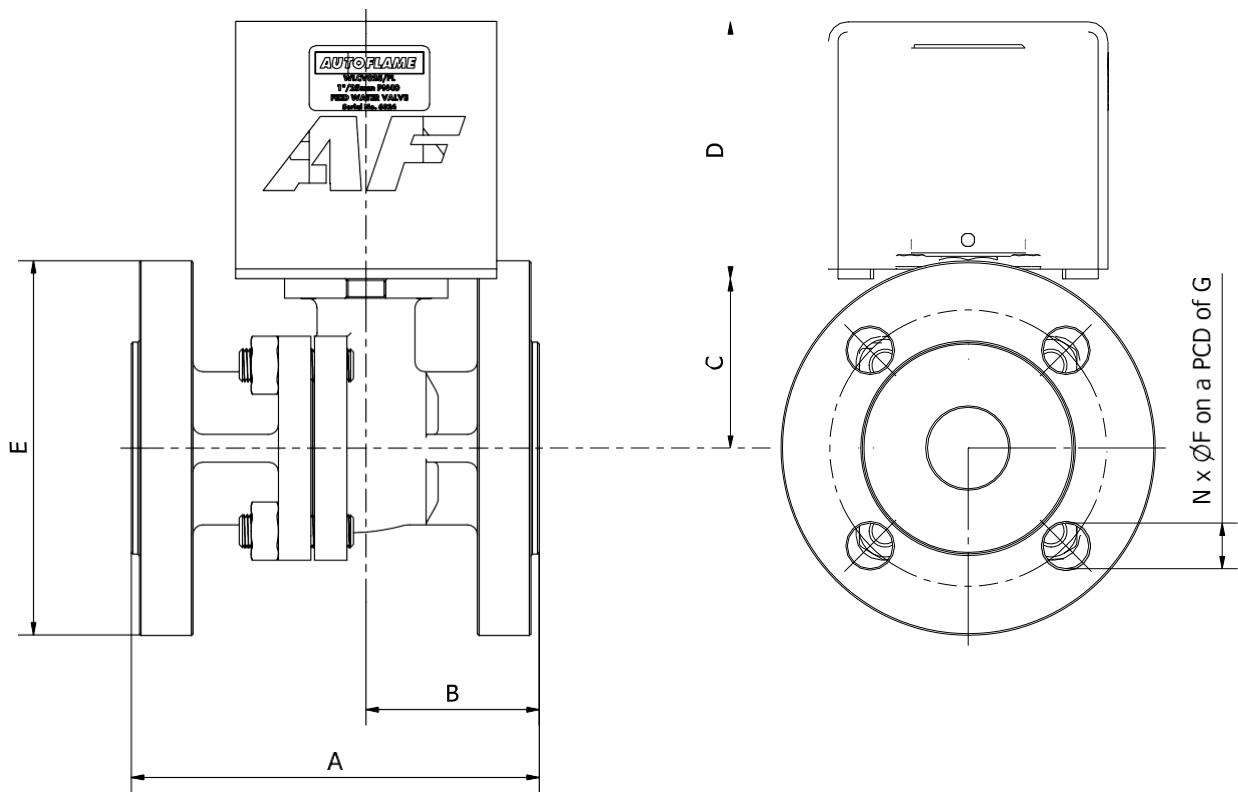

Part #	Dimensions: mm								
	Size	A	B	C	D	E	F	G	N
WLCVO25/FL	25	125.0	53.0	52.0	76.0	115.0	14.0	85.0	4
WLCVO40/FL	40	140.0	57.5	66.0	76.0	150.0	18.0	110.0	4
WLCVO50/FL	50	150.0	63.0	74.9	76.0	165.0	18.0	125.0	4
WLCVO25/FLU	25	165.0	73.9	52.0	76.0	124.0	19.0	88.9	4
WLCVO40/FLU	40	190.5	83.0	66.0	76.0	155.5	22.0	114.0	4
WLCVO50/FLU	50	215.9	100.0	74.9	76.0	165.0	19.0	127.0	8

Part #	Dimensions: inch								
	Size	A	B	C	D	E	F	G	N
WLCVO25/FL	1	4.92	2.09	2.05	3.00	4.53	0.55	3.35	4
WLCVO40/FL	1.5	5.51	2.26	2.60	3.00	5.91	0.71	4.33	4
WLCVO50/FL	2	5.91	2.48	2.95	3.00	6.50	0.71	4.92	4
WLCVO25/FLU	1	6.50	2.91	2.05	3.00	4.88	0.75	3.50	4
WLCVO40/FLU	1.5	7.50	3.27	2.60	3.00	6.12	0.87	4.49	4
WLCVO50/FLU	2	8.50	3.94	2.95	3.00	6.50	0.75	5.00	8

5.3. Feed Water Valve Sizing

The table below provides data about flow velocity, pressure drop and flow rate for each water valve.

Water flow calculations @20°C

Water Velocity		Pressure Drop Across Valve		Water Flow Rate			Steam Flow Rate	
ft/sec	m/sec	ΔP PSI	ΔP Bar	G/hr (imp)	G/min (imp)	g/min US	lbs/hr	kg/hr
WLCV015 - ½" Feed water valve								
6	1.82	1	0.07	160	2.6	3.2	1600	727
9	2.74	2	0.14	235	3.9	4.7	2350	1068
15	4.57	5	0.34	380	6.3	7.6	3800	1727
21	6.40	10	0.68	560	9.3	11.2	5600	2545
26	7.90	15	1.03	700	11.6	14	7000	3182
32	9.73	20	1.38	820	13.6	16.4	8200	3727
WLCV020 - ¾" feed water valve								
8	2.43	1	0.07	460	7.7	9.2	4600	2090
12	3.65	2	0.14	665	11	13.3	6650	3022
19	5.79	5	0.34	1100	18.3	22	11000	5000
28	8.53	10	0.68	1630	27.1	32.63	16300	7409
34	10.34	15	1.03	2000	33.3	40	20000	9090
40	12.16	20	1.38	2400	40	48	24000	10909
WLCV025 - 1" feed water valve								
13	3.96	1	0.07	1560	26	31.2	15600	7091
21	6.4	2	0.14	2300	38.3	46	23003	10456
32	9.75	5	0.34	3800	63.3	76	38005	17275
46	14.02	10	0.68	5600	93.9	112	56007	25458
60	18.24	15	1.03	7000	116.6	140	70008	31822
70	21.28	20	1.38	8200	136.6	164	82011	37278
WLCV040 – 1 ½" feed water valve								
17	5.17	1	0.07	4700	78.3	94	47005	21366
25	7.60	2	0.14	6700	11.6	134	67007	30458
39	11.86	5	0.34	11200	186.6	224	112015	50916
60	18.24	10	0.68	16500	275	330	165022	75010
75	22.80	15	1.03	20000	333.3	400	200028	90922
90	27.36	20	1.38	24000	400	480	240033	109126
WLCV050 - 2" feed water valve								
21	6.38	1	0.07	10000	166.6	200	100014	45461
31	9.42	2	0.14	15000	250	300	150020	68191
46	13.99	5	0.34	24000	400	480	240033	109106
72	21.89	10	0.68	36000	600	720	360049	163659
85	25.84	15	1.03	44000	733	880	440061	200028
110	33.44	20	1.38	51000	850	1021	510072	231851

5.4. Coupling Open and Closed Positions

Closed Position

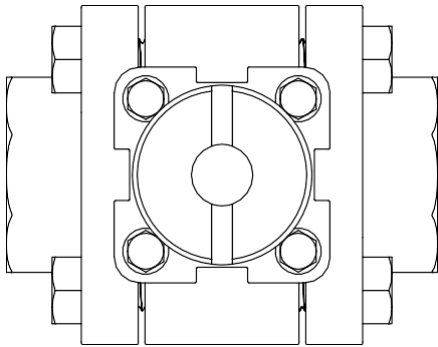

Open Position

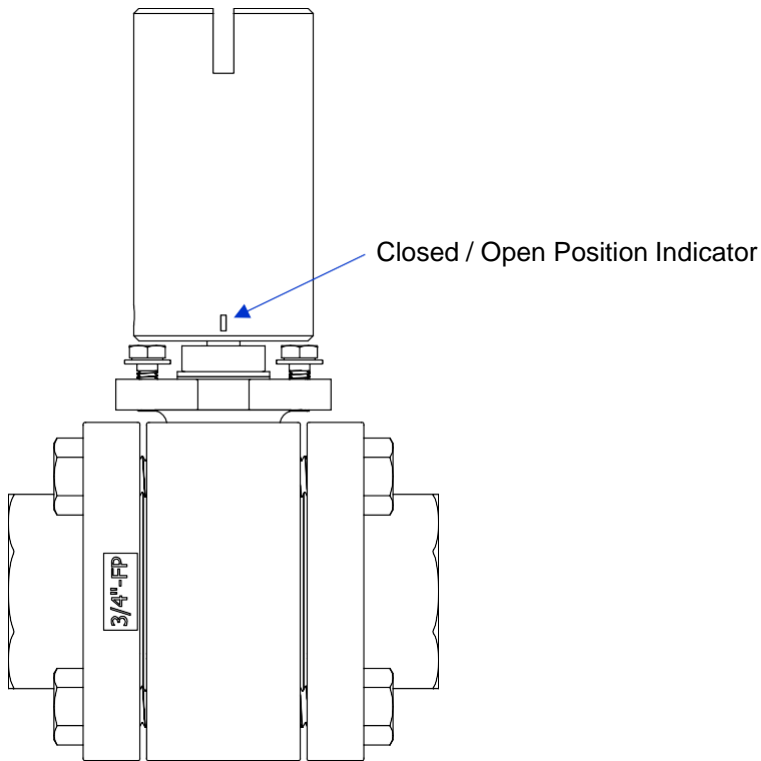
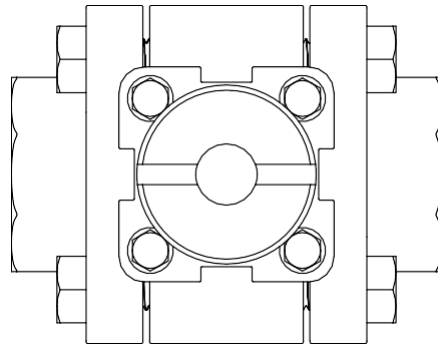

AUTOFLAME
VALVES GUIDE
04.08.2020



Fiammac Group (Engineering & Procurement)

Tel: +98 913 007 4090 (Technical consultation)
+98 913 007 5090 (Commercial, Sales)
+98 913 007 8050 (Service, Installation)
+98 912 007 6045 (Supervisor)

Email: info@fiammac.com
Supporting Email: G.fiammac@gmail.com
Website: www.fiammac.com